



• THE •
PIANOLA
JOURNAL

The Journal of the Pianola Institute

No. 26 2019

Contents

Editorial

On the Right Track:
Dynamic Recording for the Reproducing Piano
(Part Five): Rex Lawson

Claire L'Enfant and her Family: Rex Lawson

Kenneth Caswell (1931-2018) - Welte-Mignon Supremo:
Denis Hall and John Farmer

The Metrostyle: The Aeolian Company

Notes on Contributors



Contents

Editorial

On the Right Track:

Dynamic Recording for the Reproducing Piano (Part Five): Rex Lawson

Claire L'Enfant and her Family: Rex Lawson

Kenneth Caswell (1931-2018) - Welte-Mignon Supremo:

Denis Hall and John Farmer

The Metrostyle: The Aeolian Company

Notes on Contributors

© The Pianola Institute 2019

All Rights Reserved

British Library Cataloguing in Publication Data

The Pianola Journal - Vol.26

1. Player-piano - Periodicals

I. Pianola Institute

789.72ML 1070

ISSN 0952-6323

The Pianola Journal is published by the Pianola Institute Ltd,
Registered Office, 111a Station Road, West Wickham, Kent BR4 0PX.
Registered in England number 1937014.
Registered Charity number 292727.

Website: **www.pianola.org**

The aims of the Institute

A small number of pianola owners and musicians have been concerned for some time at the unnatural break between the world of music rolls and the world of music. Few members of the musical public know much about player pianos, and the Institute aims to bring about a better understanding and appreciation of the instrument in a number of ways.

The Institute publishes a regular journal, presents public concerts, and occasionally stages a travelling exhibition. It has an informal roll and information archive, with a small collection of player pianos for listening and study purposes. From time to time it publishes accurate editions of both new and re-copied music rolls.

The Pianola Institute will endeavour to preserve, research and document the pianola's history, to improve the instrument's present standing, and by the commissioning of new compositions, to ensure that it remains an important musical force for the future.

The Directors of the Institute are:

Francis Bowdery, Keith Daniels, Mike Davies, Denis Hall, Eileen Law,
Rex Lawson and Clive Williamson.

It is possible to support the work of the Institute by joining the Friends of the Pianola Institute. The Friends' subscription includes a copy of the Journal and regular newsletters. Membership enquiries may be made by post, to Adrian Church, 168 St Anne's Hill, London SW18 2RS, England, or via the Friends' section of the Institute's website at:

www.pianola.org/friends/friends_enrolment.cfm

For 2019/20, subscriptions, which include postage and packing, are as follows:
UK and EU - Individual £14 Joint £15
Rest of the world - £22

Libraries and other institutions may subscribe to the Pianola Journal.
For 2019/20, institutional subscription rates, which include postage and packing, are: UK and EU - £15 Rest of the world - £25

Overseas subscriptions should be made payable in sterling. All membership payments may also be made via Paypal to: **payments@pianola.org** - please include full details.

Editorial

Sadly, I must write this editorial by recording the passing during the last year of three special friends who have, in their own particular way, played important roles in the life of The Pianola Institute.

Claire L'Enfant died on 22nd August 2018 after a long illness. As a Director and our Company Secretary since the inception of the Institute, her hard work, sound judgment, professional expertise in publishing and in particular her very special friendship have contributed in a unique way to the success of all our efforts - she will be greatly missed. Rex Lawson writes a personal remembrance of her.

Ken Caswell was not an active member of any of the player piano societies, but in his way he contributed enormously to the appreciation of piano roll recordings, particularly in America. His death in February 2018 robbed the world of a true enthusiast for the musical value of the reproducing piano. This, and his inimitable Southern sense of humour, made him unique.

Finally, Richard Baker, best known as a broadcaster, died on 17th November 2018. He introduced the inaugural Queen Elizabeth Hall concert which launched The Pianola Institute in 1985, and three years later he presented the Last Night of the Proms on BBC Television, when we revived Percy Grainger to play the Grieg Piano Concerto. My memory of him on both occasions was that he was enthusiastic, friendly, and entered fully into the player piano scenario for us. We were very lucky to have had his support.

Our reprint article from 1903 on the Metrostyle is an interesting period piece, with its extravagant claims for what the device could do. The author puts up a strong case for the Metrostyle line, in that by following it, with careful use of the Tempo control, the Pianolist could recreate the interpretations of the great virtuosi whom they might have heard on the concert platform. But to suggest, as the article does, that these virtuosi had mastered playing the Pianola to such an extent that they themselves could indicate all the subtleties of their interpretations on a metrically cut roll is a breathtaking claim. Metrostyle lines these days seem to be largely ignored by Pianola enthusiasts, but in my experience, many of them do work extremely well, and they can be a useful aid to sensitive Pianola playing. They are also convincing evidence that there must have been some very fine Pianolists in the early years of the twentieth century.

Our main contribution in this issue comes from Rex Lawson, who, over the past two years, has discovered much new material about the Duo-Art piano. We thought we knew just about all there was to know about the system. How wrong we were!

Denis Hall

On the Right Track

The Recording of Dynamics for the Reproducing Piano (Part Five)

Rex Lawson

DYNAMIC RECORDING SYSTEMS

5 - The Development of the Duo-Art

Preamble

I've deliberately tried to write these articles on dynamic recording as a unified series, in part so that they might one day be available as a separate resource. On the whole they have not been an overall history of the main reproducing piano systems, but in the case of the Duo-Art, such a lot of evidence has survived, especially with regard to the editing of its music rolls, that it seems sensible to begin this particular essay with a look at the social, musical and technical background that led to the instrument's invention and development. The discussion and analysis of the Aeolian Company's later dynamic recording methods will therefore appear in *Pianola Journal no. 27*, whereas the earlier stages of development form the basis of this current article.

A few years ago I noticed that some important US patent litigation files on the subject of dynamic recording had survived at the US Patent Office Archive at the University of Maryland. Full marks to the Internet for making such discoveries possible! As a result I was able to purchase scans of all the surviving papers of an important patent interference action, involving the Aeolian Company and Wilcox & White, two major player piano manufacturers, both founded in Meriden, Connecticut. In the light of history, Aeolian was very definitely the more important company of the two, but it lost this particular legal action. However, in its efforts to provide evidence of its priority of invention, it brought forward a number of expert witnesses, who between them provided a detailed account of the early development and intended recording methods for the Duo-Art.

But before we embark on any examination of the history of the Duo-Art, I first need to note my debts of gratitude to a number of people - experts, enthusiasts, friends and collectors - whose combined insights have rendered the Duo-Art the most widely discussed reproducing piano of its period. One doesn't discover the most fruitful paths of research in isolation, nor come to conclusions about the nooks and crannies of player piano history without the help of friends and acquaintances, both past and present. As we all know, not every enthusiast has the intention of sharing knowledge, and sometimes the real insights arise more out of what people choose not to say, rather than from their published comments. But in the end the truth will out, and the international nature of the Duo-Art has helped to preserve a great deal of source material in the long term.

Dealing first with those who are no longer with us, one remembers discoveries laced with affectionate and sometimes errant human beings! The late Gerald Stonehill, an important Duo-Art collector who died in 2011, was kind enough to arrange for Denis Hall and me to purchase the late Gordon Iles' non-Duo-Art music rolls, when Gordon died in 1983. At least Gerald thought they were non-Duo-Art rolls! Actually, Gordon's Artona master rolls included many issued Duo-Art rolls, and also a good number of factory patterns, plus a few originals from the London Duo-Art recording piano. Such rolls, amply augmented by the Creary Woods collection at the University of Maryland, throw a very detailed light on the recording and editing practices of long ago, and both Gordon and Gerald are to be commended on their thoughtfulness in preserving a good proportion of their unique resources. It is also fitting to note that the memories of seaside high teas at Gordon's and his wife Lily's boarding house in Ramsgate (in Kent, on the south-east coast of England) - ham salad, followed by jelly and ice cream, with copious cups of strong tea - will never be forgotten, and in their way they are just as important as the technical history of the Duo-Art, because they remind us of the humanity of those who worked in the player piano industry.

Our understanding of the ways in which the Duo-Art recording consoles were used by the Aeolian Company's staff producers comes from a number of sources, including the recording studio photographs that were carefully preserved by Yvonne Hinde-Smith, the younger daughter of Reginald Reynolds, Duo-Art recording producer at Aeolian Hall in London's New Bond Street. Yvonne's life began at almost exactly the same time as the Duo-Art recording project in London, since she was born in the summer of 1919, at the very moment that her father was returning by ship, after a working visit to the Aeolian Company in New York. The news of her birth was telegraphed to the mid-Atlantic, no doubt a great excitement in those far-off days, and R/R (as he identifies himself on his personal roll-box labels) duly returned to his burgeoning family responsibilities, and also to set up and run a new London Duo-Art studio from roughly the end of that year. Yvonne died in 2010, and before that she was for many years both a founder member of the Pianola Institute, and Vice-President of the Player Piano Group, which has now published these studio photographs in a handsome book, finely edited by Patrick Handscombe.¹ In her very last years, Yvonne lived with her son and daughter-in-law in the Pyrenees, along with her cat, and with a mountain on the horizon, with which she formed a certain rapport, destined, as she understood herself to be, to return to the earth from which she had come. She was a very fine lady.

The aforementioned Gordon Iles had himself recorded rolls in the London studio (and we have one of his original rolls to prove it), and his distant memories threw much light on the recording consoles' hand and foot controls.

Correspondence and published reminiscences also survive from both W. Creary Woods, the New York Duo-Art producer, and from the English pianist, Harold Bauer, which refer to the differing ways in which the Aeolian staff on the two sides of the Atlantic responded to the constant challenge of creating realistic Duo-Art dynamic coding for a wide variety of musical styles.

The inventors of the Duo-Art have in the past been curiously difficult to pin down, perhaps because the instrument was developed by a team of specialists, rather than by an individual. Edwin Votey's historical notes, prepared for the speech that he gave on presenting one of his original Pianolas to the Smithsonian Institution on December 1st, 1922, have been a great help towards the understanding of the ways in which Aeolian's research departments operated, though the Duo-Art itself is hardly mentioned. But the preservation of these papers is a matter of great good fortune, and the player-piano world as a whole owes a debt of gratitude to Ted and Pat Votey, Edwin Votey's grandson and his wife, who recognised their importance when Ted's aunt was thinking of throwing them away, and who kept them safely in a suitcase in their bedroom, against the day when some dogged researchers would beat a path to their door and unlock their secrets. The privilege of doing just that fell to Patrick Handscombe and this writer, in the late 1990s, a moment of great excitement and affectionate memories for us both.

For the last decade and more, all those of us who conduct research into the history of the player piano have benefitted immeasurably from the decision of the Musical Box Society International to fund the digitization of *Music Trade Review* and *Presto* magazines, now freely available on the website of the International Arcade Museum, at www.arcade-museum.com. It will take generations of students to harvest the detailed historical information within those pages, and we heartily thank the two sponsors. One should always remember, however, that the two publications were intended for the trade, and for the most part funded by trade advertisements, so that new developments and public demonstrations tend to be reviewed with a more predictably sympathetic tone than may always be found in the general press.

Lastly, I owe a lifetime's debt of gratitude to Denis Hall, not least for supplying my lunchtime feasts for the last twenty-five years! My wife, Rona, who manages orchestral conductors, travels all over the world to have meetings, and was once asked by the former CEO of the Baltimore Symphony Orchestra whether *'Denis is still bringing sandwiches?'* The shared travels, music and conversations that Denis and I have enjoyed since the early 1980s have played a pivotal role in our combined appreciation of the player and reproducing piano. We don't always agree, and neither should we, but in that way our decades of discussion have encouraged us towards a better understanding of the history, technicalities and musical responses of these fascinating instruments, seasoned with a healthy dose of self-criticism. Well, he knows he's wrong really!

Historical Background - Aeolian Traditions

And so we turn to the Duo-Art, and to the artistic and technical progression which brought it about. One might have thought that the Aeolian Company, with its hugely successful Pianolas, Pianola Pianos, Orchestrelles and Aeolian Pipe Organs, would have been in an ideal position to launch a fully automatic reproducing piano during the first decade of the twentieth century. After all, it had an army of technical experts, well versed in the intricacies of pneumatic and electro-pneumatic technology, a burgeoning industrial city of specially designed factories, and an officers' corps of trained musicians, some with over twenty years' experience of creating and editing standard player rolls. In addition, it had seemingly limitless capital resources, built up over three decades, with which to develop and market such an instrument. Why, then, should it have taken until March 1914 for it to launch the Duo-Art, when the Welte-Mignon was already giving public recitals in New York in 1906?

To begin to answer that question, we need to look back into the nineteenth-century. During the 1880s and 1890s, Aeolian grew and prospered as a result of roll-operated musical instruments that were deliberately designed to require human input, and its many competitors were no different. Advertisements from the time nearly always show the interaction of couples or social groups, as one person plays while another listens, or perhaps as one sings and a friend or spouse accompanies. This concept of active participation, which grew out of a society that was used to creating its own music, was an integral and intentional part of the magic, and it is not simply to be sneered at in comparison to our own more passive domestic tastes, which favour listening to the performances of professional musicians, rather than making music ourselves.

The Aeolian Company initially grew out of the manufacture of small instruments, table reed organs that played only fourteen notes and were powered by the turning of a handle. During the 1880s floor-standing roll organs were manufactured, growing in size as the decade progressed, and by the early 1890s the Aeolian Pipe Organ had arrived on the market, as an instrument for the supremely wealthy. It was the genius of Harry Barnes Tremaine to persuade these wealthy capitalists, not only to invest in their own musical pleasure, but also to support Aeolian's general business as shareholders, which thereby allowed it to manufacture for the mass market, as the population of the United States increased almost exponentially. But these developments took time, and in 1898, when the Pianola first went on sale, roll-playing reed organs and piano-players were still relatively expensive, the preserve of the upper middle-class, perhaps, and so the traditions of shared music-making were still important to the class of people who were ready to purchase music on roll.

The illustrations that follow show two examples of this domestic style of music-making, the one in a very grand mansion, using an Aeolian Pipe Organ with a roll-playing console, and the other a simple Pianola on board a yacht!



Detail from an advertisement for the Aeolian Pipe Organ, USA, c.1895.



THE PIANOLA ON THE YACHT

Detail from an advertisement for the Pianola, USA, 1902

Many individual examples of personal enthusiasm for creating one's own interpretations can be found in a little book entitled *'Appreciation,'* published by the Aeolian Company in New York towards the end of 1899, and comprising a selection of letters of thanks from the owners of Aeolian roll-operated reed and pipe organs.² These were expensive instruments, so the writers tend to be wealthy individuals, perhaps business leaders or politicians, but there is a genuine and almost innocent delight that jumps out from the pages, of a sort very much in contrast to the sometimes guarded testimonials of later reproducing piano artists.

A good example of the book's style and intent is the letter written in May 1898 by the playwright, Henry Guy Carleton (1855-1910), who expressed some fairly typical sentiments of the time in a sensitive manner. His observations apply rather aptly to pianola players as well, especially to those who feature on the present-day internet!



146 West Ninety-fourth Street, New York, May 31, 1898.

The Aeolian Company

Gentlemen—After three years' experience with an Aeolian Grand, I am more than ever convinced of its value. While it is possible after a few weeks' practice to acquire sufficient skill to render even the most formidable musical compositions with the proper variations in tempo and stress, the performer never ceases to make progress, and soon perceives that the field before him is continually widening and that industry and study yield results he never dreamed were possible with the instrument.

As an educator in music the instrument has no peer. As a source of pleasure in the household it knows no equal. Even when tortured by the unskilled it is incapable of a false note, and when manipulated by one who knows its powers it yields results pleasing to the most scientific of musical scholars. It is only mechanical when guided by one who is himself merely mechanical. It has abundant soul for those who know how to appeal to it.

Henry Guy Carleton.





Mendelssohn Hall, New York City, Musical Courier, Vol. 44, no. 1, January 1902.

One can also see, in the repertoire chosen for its public recitals, how the Aeolian Company and its audiences perceived these various roll-operated instruments during the first decade and a half of the twentieth century. Aeolian in New York began advertising its in-house recitals in March 1895, at which time its showrooms were located at 18, West 23rd Street, in Manhattan. Occasionally thereafter it made use of larger public venues, such as the 1,100-seater Mendelssohn Hall, the home of the Mendelssohn Glee Club, at 119, West 40th Street, and the first public performance of the Aeolian Pipe Organ took place there, on May 24th of the same year, with Rafael Albertini as the violin soloist.

These demonstration concerts developed into a regular and long-lasting tradition, which can be traced in New York until at least 1919, and which spawned many similar series at Aeolian establishments around the world, in the Americas, Europe, Asia, Australasia and even on occasions Africa, and other manufacturers were not slow to follow suit. Since the Second World War, the musical preferences of player piano collectors have often given the impression that such instruments were overwhelmingly devoted to popular music and ragtime, but the repertoire performed at the thousands of demonstration recitals provides compelling evidence to the contrary, and it would be a very enlightening exercise if some postgraduate musicologist were to assemble the concert listings that are to be found in the New York newspaper advertisements of the time, and to report on the styles of the music and the nature of the soloists who were chosen to perform to the Pianola's accompaniment. Nearly



An Unnamed Pianolist (probably Charles C. Parkyn) and the Kaltenborn Quartet, rehearsing the Schumann Piano Quintet, Aeolian Quarterly, Vol. 3, no. 2.

all such concerts did indeed have soloists, whose contributions leavened the *do-re-mi* of solo piano music, providing a significant pointer towards contemporary musical tastes, and exemplifying the way in which the Pianola was designed to flourish within the musical milieu of the time.

These concerts were no doubt a very effective way of selling Pianolas, but the ideal of providing a universal means of self-expression at the piano was not so easy to accomplish in practice, and there were no doubt many who listened with admiration to the Aeolian Company's staff Pianolists, who were moved to purchase a Pianola for themselves, but who then found the task of playing the instrument in a musical way quite beyond them. Even in the earliest days a dynamic line was printed on Aeolian piano rolls, and perhaps it was not so difficult to pedal more heavily when the line moved to the right, and to return to *piano* when it turned left, but the more vexing question was that of tempo, and especially *tempo rubato*. This flexible method of phrasing music is what really marks out the playing of a human being, as opposed to a machine, but to apply such gradations to a metronomic roll needs either a good musical education, or else an ability to analyse what one hears from a pianist, and to develop a use of the tempo lever that mirrors such human playing. Disappointment must have ensued in many households, and such reactions no doubt found their way back to the Aeolian management, quite probably as part of the general social interaction at the regular New York concerts, and so the scene was set for someone to come up with an invention that attempted to solve the problem.

Historical Background - The Metrostyle

That someone was Francis Lincoln Young, a New York Pianola demonstrator who had been seconded to the Aeolian London subsidiary, the Orchestrelle Company, around the end of 1900, and who invented and developed his device, a detailed tempo controller used in conjunction with a red line printed on the music roll, by mid-November 1901. Young was born in Maine in February 1871, worked in Boston in the mid-1890s, and is noted in the 1899 Boston City Directory as having moved to New York City, where he joined the Aeolian Company in time for the launch of the Pianola in the autumn of 1898. He was not the only Pianola demonstrator engaged at around that time, and both Charles Cleghorn Parkyn and Carroll Brent Chilton are also mentioned in

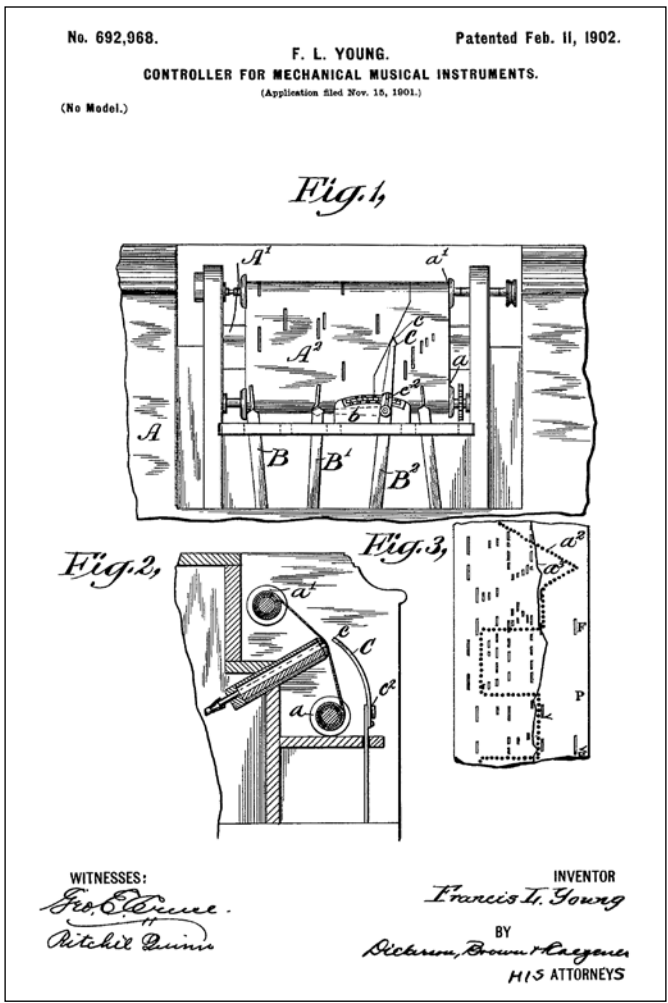

US Patent no. 692,968, granted to F.L. Young, for the Metrostyle playback system.

concert reviews, though Aeolian's determined practice of crediting the Pianola, to the exclusion of its performers, renders such references quite difficult to track down.

Young's first pair of US patents, nos. 692,968 and 692,969, were applied for on November 15, 1901, and granted on February 11, 1902, for the mechanism that came to be known as the Metrostyle. The first patent was for what we would now call the 'playback' controller, and the other for the 'recording' device. One can easily make out the spoolbox of a 65-note push-up Pianola, with its four levers, for the sustaining pedal, dynamic subduing, tempo and forward/re-roll, and the significant replacement of the simple pointer, used in playback, by the small pen used for recording the lines.

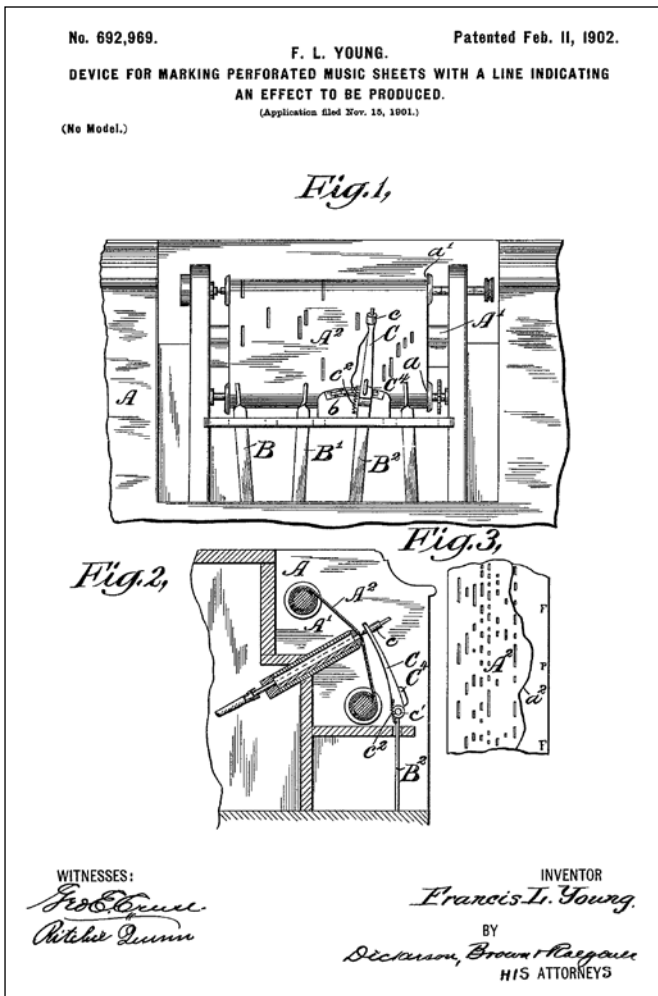

US Patent no. 692,969, granted to F.L. Young, for the Metrostyle recording system.

As we shall see later on with the Duo-Art, it took the Aeolian Company roughly a year to prepare a new instrument for the market, and so the Metrostyle was introduced commercially in February 1903, exactly twelve months after Young's patents had been granted. Also during the intervening year a library of suitable music rolls was prepared, mostly of interpretations created by staff Pianolists, but also including the first nineteen Autograph-Metrostyle rolls, supervised by the composer, Moritz Moszkowski, the pianists, Ignacy Jan Paderewski and Harold Bauer, and the conductor, Emil Paur. These four musicians are very much names from the past nowadays, but Moszkowski was one of the most popular composers of the era, Paderewski was the most famous pianist in the world, and Emil Paur was until the summer of 1902 the Music Director of the New York Philharmonic, so these first Autograph-Metrostyle rolls could hardly have come with a finer pedigree.

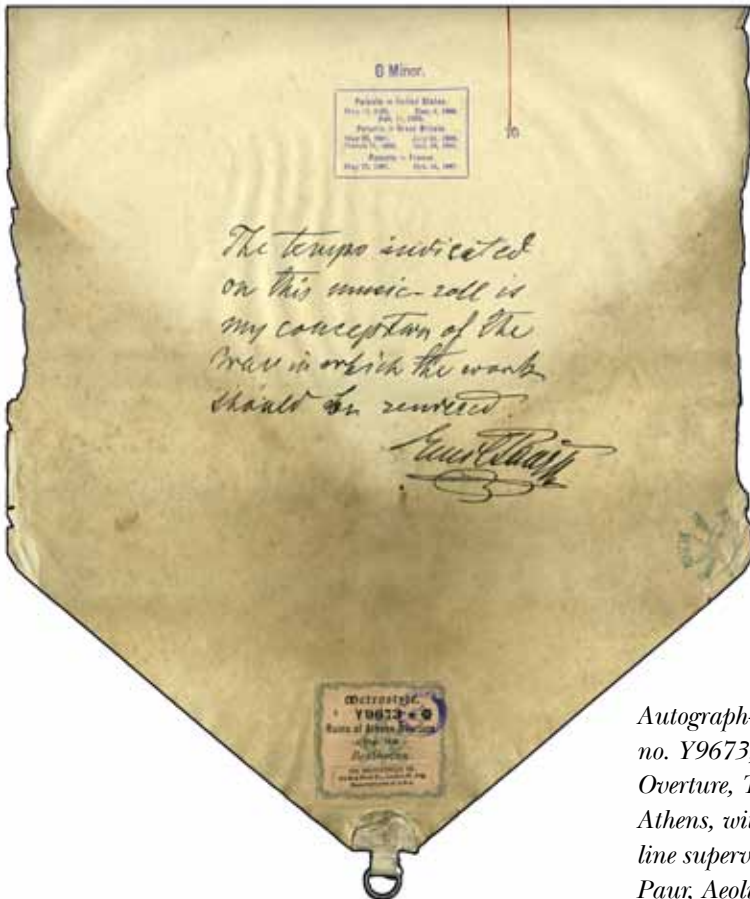

Autograph-Metrostyle Roll no. Y9673, of Beethoven's Overture, The Ruins of Athens, with Metrostyle line supervised by Emil Paur, Aeolian Company, New York, March 1903.

The first news of the new device came in an article in *Musical Courier* for February 1903, and this was reprinted as an introduction to the first Metrostyle roll catalogue, issued shortly afterwards, on March 1st. The initial public announcement in the general press followed at the end of that month. To put these events into the context of their time, the February *Musical Courier* was also reporting on the American première of Elgar's *Dream of Gerontius*, and it would be another eighteen months before the Welte-Mignon was first demonstrated in Leipzig. For those who might be interested, we have re-printed in facsimile, towards the end of this *Pianola Journal*, the introductory article, as it appeared in the Metrostyle catalogue.

To help prospective purchasers understand the Metrostyle concept, the following advertisement from the New York Sun, shared with various other newspapers, gave a pictorial representation of the new style of roll.



NOTE.—Each piece of Metrostyle music is authorized by the musician who interprets it and is printed with facsimile of this authorization, thus the "Nocturne Op. 17 No. 2," by Frederic Chopin, interpreted by I. J. Paderewski, is stamped as follows:

"This has as this roll indicates the tempo according to my interpretation."
I. J. PADEREWSKI

The METROSTYLE

An addition to the Pianola by means of which it is possible to reproduce the *exact interpretations* of the great masters of the piano.

"The METROSTYLE is the most wonderful invention ever made in music."—MUSICAL COURIER.



THE METROSTYLE is a finger or guide connected with the "tempo lever" of the Pianola. To this finger is attached a pen.

The performer—an authority—plays upon the Pianola any classical or modern composition. As he plays he guides this pen on the unwinding music-roll in accordance with his interpretation of the piece he is rendering, and thus as he plays he marks upon the roll in red ink a line which, as it progresses, indicates in all its angles and curves exactly in expression the *ritardando*, the *accelerando*, or any of the various dynamic contrasts of music, just as he himself plays it.

After the completion of this work on the roll the pen is removed, and any performer can use the finger or indicator following the red line that has been marked by the performer, and he will thereupon get an *exact repetition* of the performance as it was played by the authority.

We unhesitatingly state we believe that the Metrostyle is the most important and far-reaching improvement ever made in musical instruments, and that it rivals the Pianola itself.

Music for the Metrostyle will be interpreted by all the world's greatest musicians. (See note.)

Selections have already been interpreted and marked by Maurice Moszkowski, I. J. Paderewski, Harold Bauer, and Emil Paur.

The first catalogue of Metrostyle music (now ready) contains interpretations by each of the above virtuosos, in addition to 150 compositions interpreted by an authoritative pianist.

"This is such a stupendous innovation on everything that has taken place in music as far as that it stuns the intelligence. It is so far-reaching that it overwhirls the intellect. We see completely at the mercy of an entirely new thought in musical development. We now see piano-playing taken out of the realm of automatism and placed at one step onto the very highest rung of the ladder of individualism."
—MUSICAL COURIER, February 11, 1903.

The cost of the Metrostyle Pianola is \$300.
Purchasable by monthly payments.

The Metrostyle Pianola is on exhibition and for sale.

The AEOLIAN COMPANY, AEOLIAN HALL, 362 Fifth Ave.
Brooklyn Selling Agents.....FREDERICK LOESER & CO

Advertisement for the Metrostyle Pianola, New York Sun, 5 April 1903.

According to reports in *Music Trade Review*, Francis Young seems to have spent the summers of the succeeding years visiting Europe, in order to produce more Autograph-Metrostyle rolls, though other Pianolists are on record as having contributed as well. George Reed, from the Orchestrelle Company (Aeolian's London office), visited Edvard Grieg in Norway in late July 1904 and worked with the composer on no less than 14 rolls, and Hermann Schaad, who later went on to become General Manager of the Aeolian Company, played in St Petersburg on Saturday, November 11th, 1905, to a remarkable audience consisting of Rimsky-Korsakov, Balakirev, Glazounov and Liapounov, as well as working with all of these Russian composers in order to record Metrostyle lines for their music. Not slow to sense a good advertising opportunity, Aeolian even used Schaad's cablegram as the basis of an advertisement in the national press, within eight days of his exotic recording session!

As far as one can tell from the various roll catalogues of the time, Autograph-Metrostyle rolls continued to be published until the end of 1908 in the USA, and until at least 1914 in the UK, where Orchestrelle had its own British series of specially Metrostyled rolls, including five of Elgar's First Symphony, for which Elgar himself supervised the marking process, with the aid of Easthope Martin, at that time (1911) the Orchestrelle Company's chief Pianolist.

Normal Metrostyle rolls continued for much longer, however, into the 1920s in the USA, and until the early 1930s in Britain. We know from Reginald Reynolds' memoirs that he travelled each week to the Aeolian factory at Hayes in Middlesex, to mark up a selection of Metrostyle rolls, and indeed some of his original rolls have survived. However, marking the rolls was one thing, and the production of multiple copies was quite another. Early on in the USA, Metrostyle lines were copied in very small quantities, perhaps two at a time, but increased production led to the development of machines that could mark up to fifteen rolls at once. The lines on such mass-produced rolls have to be very carefully interpreted, since they can easily be very slightly displaced, especially in time and in what we might now call resolution. This does not negate their value, but they do need to be played by musicians who are experienced at reading them.

In winding up our discussion of the Metrostyle and Autograph-Metrostyle, we shall take a look at Francis Young's own description of the reception given to the Metrostyle Pianola in Germany, when he travelled there in the summer of 1904. Young was no doubt an ambitious man, and he is certainly not backward in mentioning his own achievements, but the interest he describes from the main professors in Berlin was clearly strong enough to have been genuine. We should remember that he is reporting to us from the very earliest years of the twentieth century, just before the Welte-Mignon arrived on the scene, and the next four pages contain a transcript of his letter, forming a four-page Aeolian advertisement that was placed in several magazines of the period, in late 1904.

The Artistic Triumphs of the Pianola in Germany

WITHIN THE past few months, the Pianola has been accorded a recognition in one of the greatest musical centers of the world, which is perhaps more significant than any of the many tributes which have preceded it.

The Germans, as a people, are noted for their conservatism, especially in all matters affecting innovations in music and the fine arts. The following letter to the President of The Aeolian Company gives an account of the experiences of a gentleman from the London office of The Aeolian Company, who made a brief visit to Germany last summer.

The matters treated of are of such general interest and of such vital importance to the entire musical world, it has been decided to make the communication public in its original form.

The Orchestrelle Company

Mr. H. B. Tremaine
President Aeolian Company
New York

English Branch of The Aeolian Company

London, August 3, 1904.

DEAR SIR: In some respects my recent trip abroad was the most interesting and most successful of any which I have taken. I was enabled to demonstrate the capabilities of the Metrostyle Pianola to some of the greatest living musicians, and it is an interesting fact that in each and every case the artist at first refused to hear the instrument, giving as his reason his objections to mechanical instruments, however perfect, and the fact of having heard instruments of a similar character before and having his opinion verified after the demonstration. I never before realized the innate prejudice a musician has against instruments of this kind, and it more forcibly than ever made me realize the importance of constantly continuing to improve our instruments, so that the customer may not only be enabled to play intelligently, but be prevented from playing in such a way as to create a wrong impression in the mind of the auditor.

The first great artist to whom I played in Berlin was Joachim, who is not only considered the greatest violinist of this age, but whose opinion upon all things musical is taken as a criterion by musicians the world over. Being a violinist, he was naturally more sensitive than the pianoforte virtuosi, and while I looked forward to showing him the instrument, I realized that his judgment and criticisms, if he had any to make, would be of great value to us, but an unfavorable impression expressed to brother musicians might make our work all the harder. I played to Joachim several compositions of different kinds, and his opinion is best expressed by the testimonial which he gave us and which seems to me to be of the greatest possible importance, coming as it does from this renowned

GENTLEMEN: I consider your Pianola with the Metrostyle an invention of the greatest importance to musical art. My first impression upon hearing an instrument of this kind was that it would be harmful and misleading; but the Metrostyle Pianola has completely changed my opinion, for not only does it play the notes correctly, but, with the Metrostyle, interpretation is given which is equal to that of an artist. Your success is assured.

Yours truly,
JOSEPH JOACHIM.



JOSEPH JOACHIM

SCRIBNER'S MAGAZINE ADVERTISER

To FRAU WAGNER, Bayreuth, Germany.

BERLIN, June 16, 1904.
 MY VERY DEAR MADAM: Mr. Muetter, the representative of The Aeolian Company in New York, has asked me to give him a word of introduction to you; this I do very gladly indeed, as the instrument which he wishes to display to you fulfills very wide requirements. Not only can the most difficult piano compositions from Bach to Liszt be reproduced with the greatest ease, but all possible shades of rendition are also possible. More important than all this, however, appears to me the so-called Metrostyle device, which puts us in a position to make permanent records of the finest tempo-nuances and so to leave to following generations an authentic tradition in black and white.

Just at this time you will find yourself in the midst of most exacting work. We also hope in some weeks to appear on the scene, and Wolfram takes endless pleasure from the fact that he will be able to be present at the last rehearsals. He is now already studying, besides syntax and algebra, most industriously the "Ring" in order to prepare himself.

With heartiest greetings to all Wahafried, in which all my family join, I remain, in the pleasant hope of seeing you soon,

(Signed)

E. HUMPERDINCK.



E. HUMPERDINCK

BERLIN, June 3, 1904.

THE AEOLIAN CO.

GENTLEMEN: The Metrostyle Pianola which I have just heard has filled me with admiration and wonder. Although I have heard instruments play the piano before, I had no idea that it was possible to play with the taste and expression of an artist, and the Metrostyle, it seems to me, is almost as valuable as the instrument itself. Your success with the Metrostyle Pianola should be very great.

I am, yours truly,

E. HUMPERDINCK.

and esteemed musician. Joachim seemed to think, however, that the Pianola required a highly trained musician and that a novice might convey the wrong impression of the work. Therefore he insisted, as you will see by his letter forwarded herewith, that the Metrostyle was not only valuable and interesting, but *indispensable*.

The next musician who was persuaded to call at our warerooms in Berlin was Humperdinck. Like all of the others, he at first flatly refused to listen to the Pianola. He had never heard the instrument, but classed it with the others which were supposed to produce the same result; but after repeated calls we finally persuaded Humperdinck to accompany us to our office in Berlin, where I played to him both on the Orchestrelle and on the Pianola. It is, of course, impossible for me to describe the enthusiasm displayed by these different artists and composers, but in the case of Humperdinck it seemed as if he were struck with silent wonder, as he seemed so entirely at a loss to express himself. His opinion of the instrument, however, is best shown in the letter which he afterward sent us. Humperdinck is not only one of the most prominent composers of operatic music of to-day (having written "Hansel and Gretel," one of the most successful operas produced in a decade), but was one of the most intimate friends of Wagner and was one of the first directors of "Parsifal" at Bayreuth. Humperdinck inquired whether Madam Wagner had heard the Pianola or the Orchestrelle, stating that he thought she would be very greatly interested in them. We informed him that we believed Madam Wagner had not yet heard the instruments and Humperdinck thereupon gave Mr. Muetter a letter introducing him to Madam Wagner. This letter is in itself, it seems to me, a testimonial of the greatest importance to us, and I enclose herewith a copy of the letter which has been translated from German into English.

Perhaps the most important musician to whom I played in Berlin was Professor Barth. This gentleman is considered one of the greatest piano-teachers living and was the intimate friend of some of the greatest composers, such as Brahms, etc., and occupies one of the most important positions, as a teacher, in Europe. Being a teacher of such prominence and such experience, he naturally would listen to the performance of the Pianola differently than any other musician to whom I have ever played, and after the usual absolute refusals to listen to the instrument, he was finally persuaded to give us, as he said, "just five minutes."

It may be interesting at this point to tell you something of the music which I played. Among other compositions was a long roll by Rosenthal, known as "Theme and Variations." This composition contains not only some of the most difficult passages ever written for the piano, but is so varied as to require almost every shade of variation known in pianoforte-playing. I had already played to Mr. Barth several other compositions, and after his five minutes had been lengthened to over an hour, I played the above composition. Having heard instruments which played the piano automatically before, he was under the impression that he knew the different things which could not be accomplished in playing the piano this way. Mr. Muetter, therefore, while I was playing, called the professor's attention to certain things which I was actually doing

SCRIBNER'S MAGAZINE ADVERTISER

and which Professor Barth claimed were really impossible. Each time that Mr. Muetter attempted to speak, the Professor would raise his hand and request him to be silent, showing how intently he was listening to every phrase, bar, and note which I was playing. You will perhaps be interested to know that in not one single instance did Professor Barth criticize any feature; but after I had finished the composition by Rosenthal, Professor Barth said in German: "Now that it is possible to play a composition like that so perfectly, by whatever means, the most prominent teachers and advanced students of the Hochschule should hear this instrument and take its performances as a type of perfection."

He then inquired whether or not we would be willing to give a recital to the teachers and students of the Hochschule—and I might mention that the Hochschule in Berlin is the first conservatory of Germany and one of the most important in the world. Dr. Joachim is the Director, and other great musicians, such as Max Bruch, the great composer, and Professor Barth, are instructors. A recital was thereupon arranged and was given in the hall of the Hochschule before all the professors and two hundred of the most advanced students. Each number on the programme was most enthusiastically applauded, and the success of the recital means to us, in Germany at least, more than anything which has heretofore been done. Without solicitation upon our part they have presented us with an official letter signed by the Directors, and I am enclosing a copy of this letter translated into English.

One incident which happened at the recital will perhaps be of interest and show the seriousness of the occasion and prove that the performances were listened to as if an artist had been playing, and that *during the performances of the music, the means of producing it were forgotten.*

Each number, before it was played, was announced by Dr. Joachim, and the last number on the programme was the above-described composition by Rosenthal, which was played on this occasion at the request of both Dr. Joachim and Professor Barth. Rosenthal, who happened to be in Berlin, had been invited to attend the recital and sat on the platform during the performance of this number beside the player and indicated from time to time, almost involuntarily, the tempo in which the variations should be played. After several variations had been performed, Rosenthal was obliged to make his acknowledgments to the applause, and after the last variation, which is of the greatest brilliancy, the applause was tremendous, and both the performer and Rosenthal were obliged to repeatedly bow. The performance of this piece was an event in more than one way, as I believe it has never been played in public before, having just been published, and certainly never in Berlin. None of the musicians or artists to whom I played it had ever even heard of it.

There is perhaps no musician in Europe whose opinion I value more than that of Carl Reinecke. He is supposed to be the greatest exponent of Mozart of his day. Many pianists of the highest rank, and students who have had instruction from the best teachers, have in most cases gone to Reinecke for the purpose of getting his interpretation and ideas in connection with the compositions of Mozart.

KÖNIGLICHE AKADEMISCHE
HOCHSCHULE FÜR MUSIK IN
BERLIN.

CHARLOTTENBURG,
den 14. Juni, 1904.
FAHREN STR. 1.

In the presence of the undersigned and a great number of teachers and scholars of the Royal Academy, Mr. Muetter yesterday conducted in one of the large rooms of the Institution a demonstration of the Metrostyle Pianola. Among the works given, two compositions, namely, the variations of Pachelski, and the variations of Rosenthal, both compositions for the virtuoso of the most extreme difficulty and brilliant effect, were produced. It is astonishing how much freedom of movement can be shown, both as regards dynamic and rhythmic effects, by a skilful handling. So far as the limits allow, if indeed any exist, the abilities of this device, as compared with the living personal rendition of an artist, have reached the highest result obtainable.

**JOSEPH JOACHIM.
ERNST RUDORFF,**

Professor and President of the
Department for Piano and
Organ in the Royal Acad-
emy for Music in Berlin.



CARL REINECKE

LEIPZIG, den 10. Juni, 1904.

GENTLEMEN: The Pianola has pleased and astonished me, the more because of its great improvement over the others of its class. Upon no other instrument I have heard is the touch so perfectly controlled, and the Metrostyle seems to me to be almost as great an achievement as the instrument itself, for without an intelligent interpretation a composition, however well executed, is of little value. Please accept my best wishes,

Yours truly,
CARL REINECKE.

SCRIBNER'S MAGAZINE ADVERTISER

Perhaps no composer has ever lived whose music requires such careful interpretation as Mozart, the phrasing of each bar being of the greatest possible importance. Therefore I anticipated great difficulty in persuading Reinecke to hear the Pianola. I should have felt that we had achieved something of great importance if Reinecke had merely listened to the instrument, realizing the natural aversion he must have to any music from the pianoforte not produced by human fingers. Perhaps no person living is better qualified to judge correct pianoforte-playing and -phrasing than is Carl Reinecke. Therefore the endorsement which he gave us seems to me to be all that any musician or musical person would require as proof that the Pianola is capable of producing from the piano, music, however difficult, as well as it is possible for such music to be played.

I think I need not say anything further about the other musicians in Berlin, as their letters can best describe their opinions; but, before I left, several of the most prominent had commenced to indicate their interpretations with the Metrostyle, either of their own compositions or those for the performance of which they were famous, among others, Professors Barth, Busoni, the great pianist, and Humperdinck.

We have just received an endorsement for the Metrostyle Pianola from the great Saint Saëns, and you have undoubtedly received my cable message concerning it. When one considers his strong opinions against instruments of this kind, obtaining his endorsement is a positive achievement.

Before closing I wish to speak of what I consider not only the most important endorsement we have received, but the greatest tribute ever paid by a musician to a musical instrument—the letter from Dr. Edvard Grieg. I need not speak of this great composer or his works, as they are so well known, but I send you his letter with much pleasure, and believe you will agree with me that the Metrostyle interpretations which he has given us will be of inestimable value for years to come to all who possess them, as they will constitute the only existing record of the great master's ideas as to the performance of his own compositions.

Yours very truly, *Francis Young.*

BERGEN, NORWAY, July 28, 1904.

I have heard the Metrostyle Pianola and consider it most admirable and interesting. Before hearing the Metrostyle I had thought that all such instruments were only machines, but it is indeed surprising what can be done with the Metrostyle in reproducing musical works in the way of giving the intentions of the composer. It is excellent.

EDVARD GRIEG.



EDVARD GRIEG

The Metrostyle will hereafter be incorporated in all Pianolas. Prices, \$250 and \$300

THE SUCCESS of the Metrostyle has proved it to be as important to the Pianola as the Pianola itself is to the piano. The great musical authorities have expressed this opinion with remarkable unanimity, giving emphasis to the Metrostyle's value both to the student and to the novice. Many have written that they considered it an essential feature of the Pianola, and some have even said that they would not give serious consideration to any piano-player which was not equipped with the Metrostyle.

The consensus of opinion in this direction being so strong, both among musicians and the general public, it has been decided by the manufacturers that the Metrostyle will hereafter be incorporated in all Pianolas—both in the \$250 as well as in the \$300 models.

The Pianola in its present form furnishes not only a perfect technique in playing the piano, but, *in addition*, an authoritative guide to an artistic interpretation. Although sold at the same price as other piano-players, the Pianola has in the Metrostyle an exclusive feature, which is *not even approximated* in any other instrument of this nature.

Catalogue N sent upon application.

THE AEOLIAN CO., Aeolian Hall, 362 Fifth Ave., near Thirty-fourth St., New York
124 East Fourth Street, Cincinnati O.

Historical Background - The Themodist

While the Metrostyle did not play an important technical part in Aeolian's journey towards the Duo-Art, it nevertheless provides a fascinating insight into the ways in which the Company regarded its instruments, as the facilitators of amateur interpretation, rather than the reproducers of fixed professional performances. The Themodist, on the other hand, although it was undoubtedly an important musical improvement at the time, derives its main significance in the progression towards the reproducing piano from its inclusion as part of the final dynamic control system for the Duo-Art.

One can read in many sources that the Themodist was invented in 1900 by James Crooks of Boston, Massachusetts, but the truth is rather more complex. Crooks applied for three similar patents between May 1900 and September 1901, all using marginal perforations in a music roll for purposes other than playing individual notes. His second and third patents were for the automatic changing of manuals or stops on reed or pipe organs, but the first one, granted in December 1900, was for the accurate placing of accents in an early style Pianola with no pneumatic division between treble and bass. Crooks talks of *theme-notes*, which he wishes by means of his invention to play more prominently than the rest of the perforated music, but nowhere does he mention the trade name of Themodist, and his accent signals are single perforations of the same size as the playing notes, and located at the bass side of the roll only.

In fact Aeolian had been trying to find a suitable method of bringing out accents as soon as the Metrostyle had reached the market. Francis Young had applied for an accenting patent in March 1903, which used a variation of his Metrostyle pointer to select a single perforation or a small range on the tracker bar, in conjunction with a curved lever or a sliding brass valve that opened or closed small inlet ports, which in their turn operated pneumatic valves in order to provide extra suction for the selected note or notes. Unsurprisingly, the invention did not get taken up, for it would have demanded a fearsome level of concentration for the note selection alone, leaving the Pianolist no time at all to think about matters musical.

Joseph Dickinson, who featured in *Pianola Journal no. 24*, applied for a very similar patent about two months later, and both were granted in November 1903, but the interesting aspect of Dickinson's involvement is that he followed it up with a further refinement, in which the movement of the selection lever, for the note to be accented, no longer had to be carried out by the Pianolist, but was instead operated automatically by an accordeon motor, using four coded perforations at the left margin of the music roll. Duo-Art enthusiasts will recognise the birth of one of the Duo-Art's most important dynamic components, albeit in this instance being used to select pitch rather than loudness. Compiled illustrations for both the Crooks and the Dickinson patents are to be found overleaf.

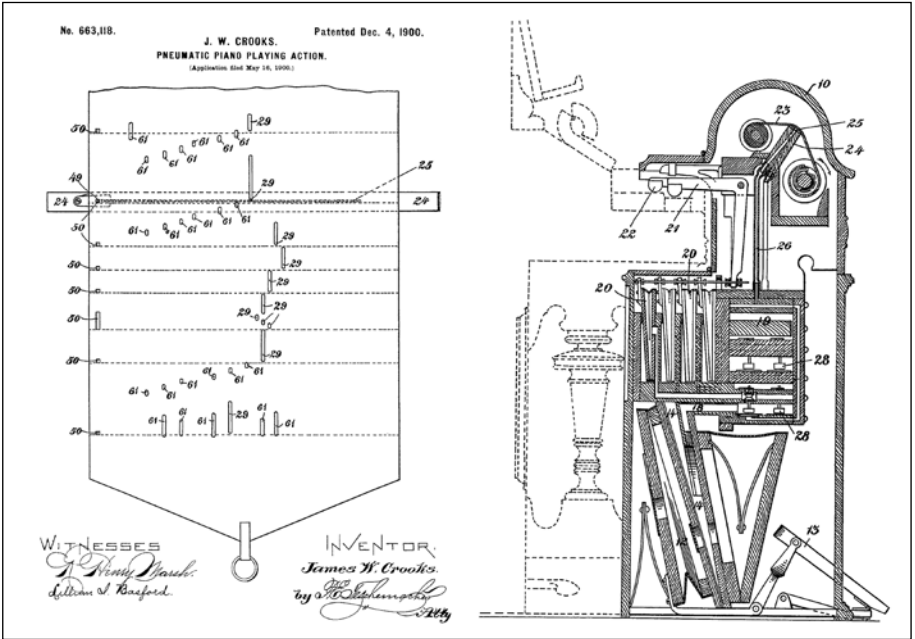

US Patent no. 663,118, granted to J.W. Crooks, for his theme-note accenting system, 4 December 1900.

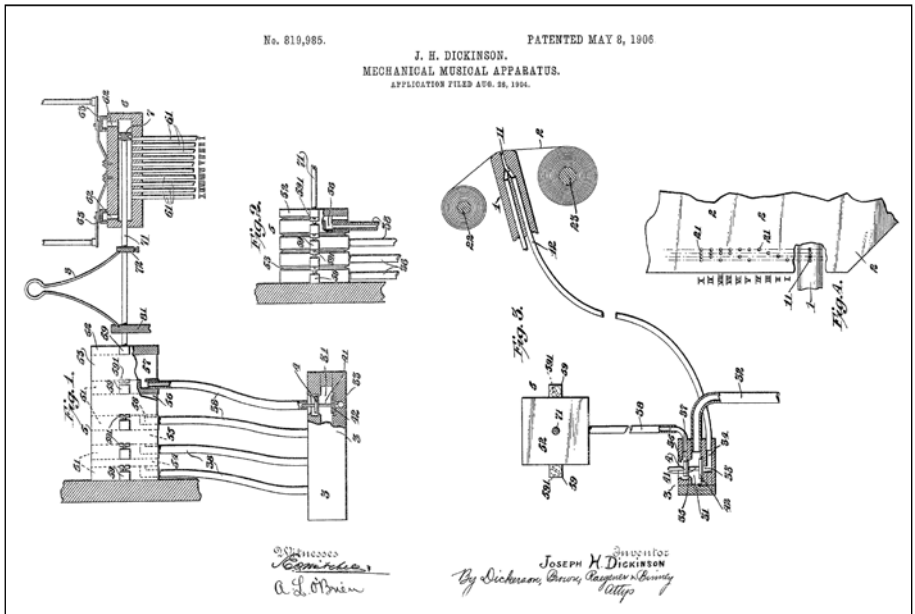

Compilation from US Patent no. 819,985, granted to J.H. Dickinson, for his accordion pneumatic device, 8 May 1906.

In the end, these overly complicated inventions were ruled out, and clearly a decision was taken to simplify the accenting device, so that it would work on the general treble or bass ranges of the piano, rather than attempting to single out individual notes. James Crooks, who had been working for the Aeolian agency in Boston, moved down to New York City in May 1906 and joined the headquarters staff, and his patent was duly acquired by the Company. According to *Music Trade Review*, the Themodist was launched in the September of that year, and the first advertisements in the press followed in October (see overleaf). The Aeolian agency in Washington, D.C., deserves a round of applause for being the first to go into print, as well as having the wit to set the notion of 'The Themodist, the Themodist, the Themodist is here' to a round of *Auld Lang Syne!*



**The
Themodist
Is Here.**

A long-sought improvement in piano-player construction is at last accomplished and is incorporated in the new model of

The Pianola

This new device accents the theme, or melody, "brings out" the proper notes in contrast to the accompaniment, and greatly enhances the artistic effects of the Pianola.

The first sample received in Washington is now on exhibition at the exclusive agency of

Sanders & Stayman Co.
1327 F Street.

Free concerts every hour.

Advertisement for the Themodist, Washington Evening Star, 27 October 1906.

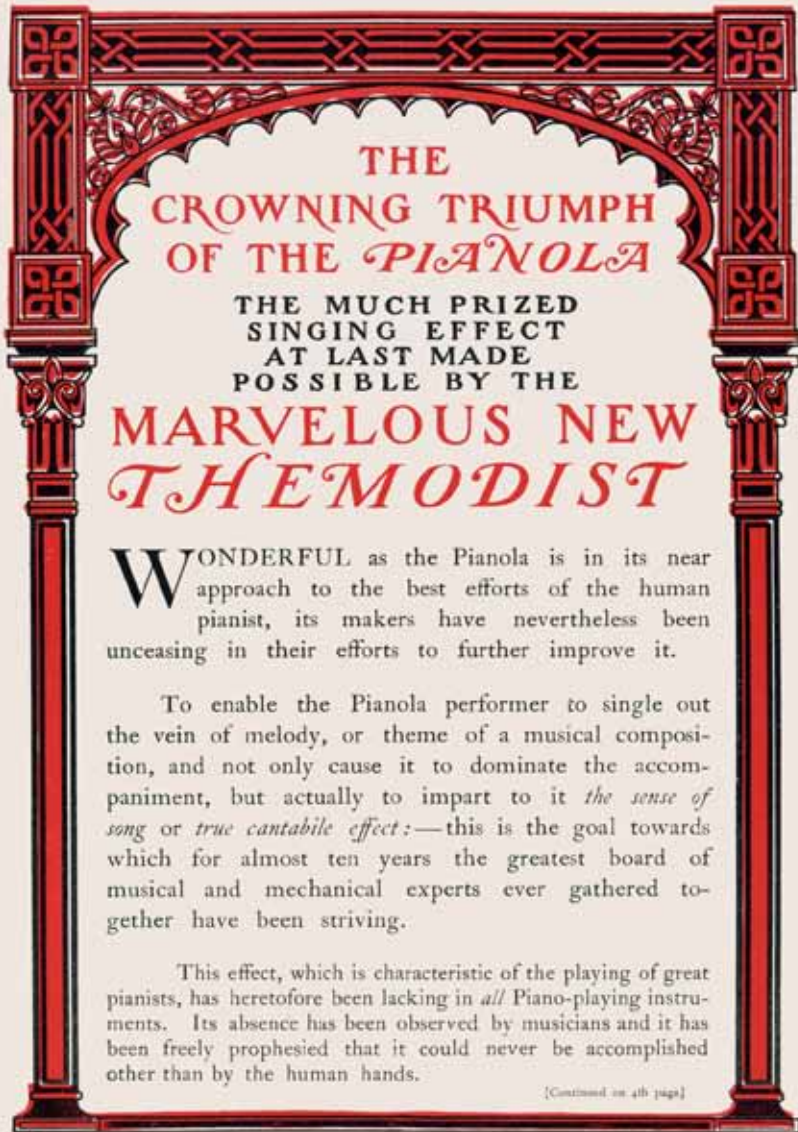

THE
CROWNING TRIUMPH
OF THE *PIANOLA*

THE MUCH PRIZED
SINGING EFFECT
AT LAST MADE
POSSIBLE BY THE

MARVELOUS NEW
THEMODIST

WONDERFUL as the Pianola is in its near approach to the best efforts of the human pianist, its makers have nevertheless been unceasing in their efforts to further improve it.

To enable the Pianola performer to single out the vein of melody, or theme of a musical composition, and not only cause it to dominate the accompaniment, but actually to impart to it *the sense of song or true cantabile effect*:—this is the goal towards which for almost ten years the greatest board of musical and mechanical experts ever gathered together have been striving.

This effect, which is characteristic of the playing of great pianists, has heretofore been lacking in *all* Piano-playing instruments. Its absence has been observed by musicians and it has been freely prophesied that it could never be accomplished other than by the human hands.

[Continued on 4th page]

THE WORLD'S WORK ADVERTISER

The seemingly impossible *has*
 come to pass, however:

*The THEMODIST
 has Solved the Problem*

This marvelous device actually *simplifies* the playing of the Pianola. With no thought or effort on the player's part, those notes which take the melody are distinctly brought out, no matter where they lie, nor how involved in the accompaniment they may be. Not only does the Themodist cause them to be struck *barder*, but the sense of pressure or firmness is given to them, causing them *to sing*, clear and sustained, as the voice of the soloist above its background of supporting instruments.

The invention of the Themodist takes rank as one of the most important achievements in the history of music. Now, for the first time, the full beauty of a Chopin Nocturne can be portrayed with a Piano-player. The inner voices, heretofore hidden by unduly loud accompaniment, now show the listener the real meaning of the composition.

With the addition of the Themodist, which, like the Metrostyle, is absolutely exclusive, the difference between the Pianola and all other instruments of its nature becomes still more apparent.

The
 Aeolian
 Company

362 Fifth Ave.
 New York

Send Catalog F and details of
 your new purchase-plan to

Name _____
 Street and Number _____
 City _____

It is the fact that the Pianola is the one Piano-player which is universally regarded as THE STANDARD. Its superiority is indicated by its sales throughout the world, which are actually GREATER THAN THOSE OF ALL OTHER PIANO-PLAYERS COMBINED.

Themodist Pianola with Metrostyle, \$300

Sold for cash or on monthly payments with interest. Other pianos and piano-players accepted as part payment. The Themodist can also be obtained in the Pianola Piano. Write for complete information about our new instruments and copy of the interesting booklet, "The Fascination of Personally Producing Music."

The Aeolian Company
 AEOLIAN HALL
 362 Fifth Ave., near 34th St.
 New York

THE WORLD'S WORK ADVERTISER

Advertisement for the Themodist, page 4.

A VIVID ILLUSTRATION THEM O D I S T

Exhibit "A," shown below, is a reproduction of the *Themodist-Marked Music Roll* of Rubinstein's Melody in F. The *Red Notes* are those accented by the THEMODIST. Compare these with the *Red Notes* in the *Piano* copy of the same composition (Exhibit "B") and it will be seen at a glance how the THEMODIST *picks out the vein of melody* wherever it may run over the keyboard, making it *stand out in prominence above all other notes*, the degree of accent being entirely at the will of the operator. The THEMODIST *subordinates the accompaniment* (represented by the White Notes), furnishing just the degree of contrast that characterizes the hand-playing of the virtuoso.

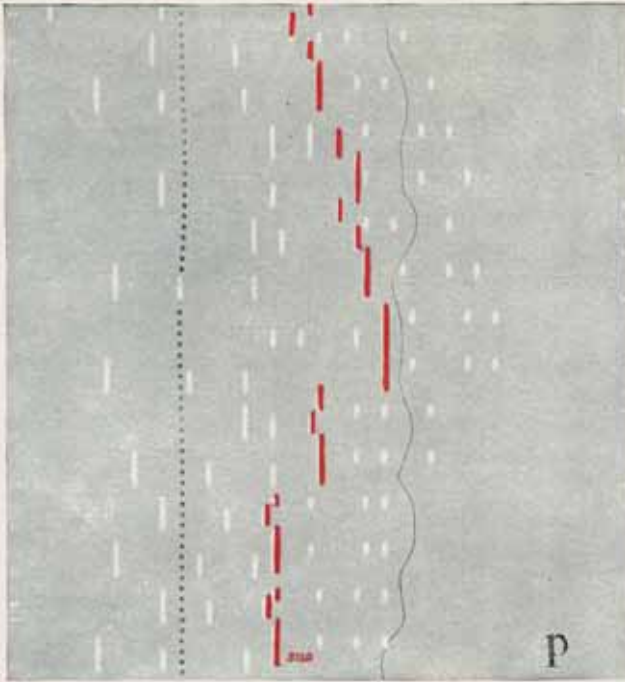

THE RED NOTES ARE THOSE ACCENTED BY THE "THEM O D I S T"

THE WORLD'S WORK ADVERTISER

OF WHAT THE NEW PIANOLA ACCOMPLISHES

Photograph of the Themodist Pianola, in Which the
Metrostyle is Also Incorporated



PRINTED BY

The red notes in the Piano copy below correspond to the red notes in the Music Roll (Standard A).

MELODY in F

First of January
1907-1910

OTTIE REINSTER,
Op. 347

Waltzes

PIANO

© Being issued here to show the ease of the machine. No.

Copyright © 1910 by the Pianola Company

1-10-10-10-10

THE WORLD'S WORK ADVERTISER

Historical Background - Hand-Played Music Rolls

By launching the Themodist, the Aeolian Company was continuing its development of ever more sophisticated means whereby its patrons could make their own music, but it is clear that it had still not appreciated the inexorable progression that would push the industry towards fully recorded music rolls. However, in late 1906 a new competitor had crossed the Atlantic, in the shape of the Welte-Mignon, which was to have a profound effect on the player piano industry, and not just in the United States. As a result of probable family disagreements, Welte did not use its existing US organisation for the Mignon, but instead set up a new company in July 1906, known as the Welte Artistic Player Piano Company, and it was not long before its instruments were winning plaudits from the musical establishment and the press alike. In public, at least, there was little sign that the American player piano companies paid the Mignon much attention, and it is quite remarkable that it took so long for any of them to comprehend the commercial importance of recorded rolls, which is to say, rolls produced from the actual playing of a pianist at a recording piano. This Damascene conversion finally made itself known in early 1912, when all the competing companies suddenly fell over each other in the effort to be the first to publish hand-played music rolls, and the palpable rush to the market is remarkable, given that there were at least three full reproducing piano systems on sale in Europe by late 1908.³

The perforation or marking up of a master roll in real time cannot have been a stumbling block, since the American engineer and businessman, George Howlett-Davis, had applied to patent his first real-time perforating machine as early as December 1894, and at least two other inventors had followed suit before 1900, with many more in the following decade. If one includes European patents as well, then sophisticated real-time marking machines had been around since the late 1880s. It is worth recording this paradox in a little more detail, since it emphasizes the technical resources that had long been available, had anyone in the USA wished to make commercial use of them.

Raoul Pugno's first encounter with the Aeolian Company's recording capabilities occurred on the evening of Monday, 15th November 1897, when Aeolian organised a New York soirée in honour of Pugno and the Belgian violinist, Eugène Ysaÿe, on the occasion of an important American concert tour that the two men were about to undertake. The event took place at the Aeolian premises at 18, West 23rd Street, and the evening's entertainment commenced at 9 pm. According to a report in *Music Trade Review*, 'it was considerably after 2 A.M. on Tuesday before the party dispersed, one of the final features ... being a duet of thanks by the honored guests of the evening.' A flash photograph was taken, and duly published in *Music Trade Review*, and it is reproduced here, clearly showing the late-night party atmosphere, and no doubt the excitement caused by the combination of a flash camera, and an opera hat which opened and closed by remote control.



Reception for Raoul Pugno and Eugène Ysaÿe at the Aeolian Recital Room, New York, 15th November 1897.

Photo courtesy the International Arcade Museum - www.arcade-museum.com

George Howlett-Davis, who can be seen wearing his experimental hat at the left of the photograph, reminisced in an interview in 1914, that, *'It was here that the first rolls taken from the perforating machine built by me during March, 1895, embodying the principles of patent No. 630,598, filed by me on December 12, 1894 (twenty years ago), covering a recording perforator for music rolls and granted by the Patent Office, were exhibited to the musicians and they all pronounced these rolls, actually made from the pianist's playing, a great advance in the art of music roll making.'*⁴ For the record, Ysaÿe and Pugno are to be seen at the centre of the photograph.

Emil Sauer also discovered the Pianola at West 23rd Street, and his experience was recorded in great detail in the *New York Sun*, in its edition for May 24th, 1899: *'Mr. Sauer was first shown the Recording piano, and played with verve and brilliancy his Valse de Concert. All the time he was playing, magnets and punches were busy registering a sort of photograph of the performance upon a moving sheet of paper. For every depression of a key, a perforation appeared in the paper, corresponding in length and form to the time the key was held down. Every note, even down to the minutest subdivision of a turn or trill, was recorded by little electric punches moving with inconceivable velocity. The paper was then spooled and placed in the roll sockets of the Pianola and the performance reproduced.'*

*'Peculiarities of touch, such as variations of strength in successive blows were absent, but the phrasing - the intellectual part - was there, so that one familiar with Mr. Sauer's style could have recognized his playing. A number of pieces followed, among them two compositions by Mr. Sauer himself, Aspen Leaves and At the Brook.'*⁵

We have here a detailed account of Emil Sauer recording at least four rolls, and probably rather more than four, for the Aeolian Company, on Saturday, 20 May 1899, just over six years and six months before he recorded for the Welte-Mignon in Leipzig. And yet neither the Aeolian Company, nor any of its American competitors, made any significant commercial use of such recordings until nearly thirteen years later, and that despite the arrival of the Welte-Mignon in New York in 1906, and the introduction in Europe of both the Hupfeld Dea and the Philipps Duca, both of which were clearly reported in *Music Trade Review* in its issue of October 3rd, 1908. Even Pleyel in Paris had been manufacturing hand-played music rolls from roughly 1907 onwards, as can be seen below, illustrated in an article in *Le Monde Musical* of that year, so by 1908 there must have been no less than four recording pianos in Europe, plus at least one in the USA. This apparent inaction by the Americans was a truly remarkable state of affairs, and it can only be explained by the fiercely strong culture of personal music-making that predominated in the English-speaking world. For more than a decade it is clear that the Anglo-Saxon player piano was regarded as a medium for self-expression, and not as a reproducing instrument.

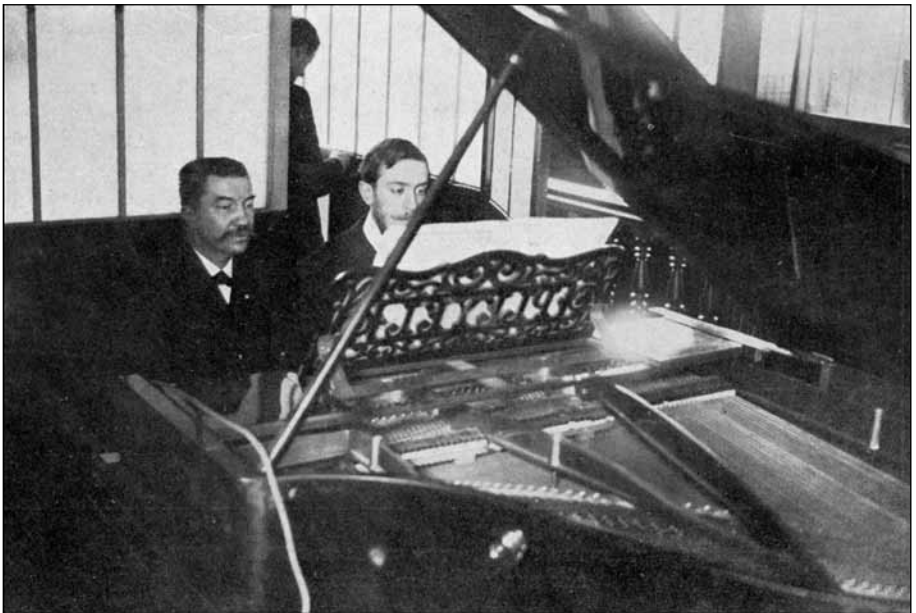

*Henri O'Kelly and Alexandre Angot recording a four-hand piano roll.
Chez Pleyel, Paris, 1907, Le Monde Musical, 15th April 1907.*

But the dam no doubt burst a while before 1912, because the various roll companies had to have developed recording pianos and the necessary perforating or marking machines to go with them, plus an initial repertoire of music rolls, and that could scarcely have taken them less than a year each to organise. Scanning the pages of *Music Trade Review* and the New York newspapers, it is possible to work out a rough timetable for what became for a while a sort of competitive frenzy, with Melville Clark's *Autograph* rolls (manufactured by QRS) being the first to be announced, on February 12th, 1912, very closely followed by the American Piano Company, whose *Rhythmodik* rolls were launched on February 17th. March 23rd saw Wilcox & White bringing out its first *Voltem* selection, and Aeolian's *Metro-Art* was announced on April 17th, in parallel with the generic *Uni-Record* rolls (without Metrostyle lines) sold by its subsidiary, the Universal Music Co. Finally, Standard Music Rolls of New Jersey published its first *Temporized* rolls on 7th September. As mentioned earlier, Europe had led the way for over seven years, with the Welte-Mignon and its competitors, and it is fascinating to see how the Aeolian copywriters of 1912 mirrored those of Hupfeld in 1905, in their thankless task of attempting to praise the superiority of hand-played music rolls over those for the full reproducing piano.

Hupfeld 1905:

*'The Phonola would not be the complete instrument that it is in reality, if it rendered the player slavishly dependent on the artists' rolls. Rather, the new invention allows the player to concentrate his whole attention on the dynamic reproduction and gradation of the music according to the indications given by the master pianist. If "His Master's Tempo" really fails to appeal to a musically educated layman, then he only has to manipulate the tempo lever in order to adjust the performance to his own taste, even with an Artist's Roll.'*⁶

Aeolian 1912 (illustration overleaf):

*'The objection to recorded rolls, as hitherto known in this country and abroad is that no matter how excellent the interpretations they portray, they play always in the same tempo and hence become finally monotonous. This objection is entirely overcome in Metro-Art Music Rolls. While it would be exceedingly difficult, for the ordinary performer to alter the interpretation on a recorded roll, the Metrostyle Line on all Metro-Art Rolls shows precisely how this can be accomplished. Indeed, this Line gives a separate and an additional interpretation and, by indicating just the places where changes can be made, opens the way for an inexhaustible variety of effects, at the command of the performer.'*⁷

The Aeolian Company Announces

Metro-Art Music Rolls

The Famous Metrostyle Music-roll, reproduced by a new process from the records of the Metro-Art Music-roll, with wonderful fidelity the distinctive characteristics of the finest hand-playing

Metro-Art Music Rolls are the latest artistic achievement of the Aeolian Company. The music-rolls are *hand-recorded*. That is, instead of being mathematically transcribed from the printed music-score as are other music-rolls, they are actual records of the performances of expert pianists.

In playing Metro-Art Music Rolls, the performer is enabled to reproduce the subtle shadings of tempo, phrasing and accent characteristic of hand-playing. Augmented by the Thermo-diat, Graduated Accompaniment, Automatic Sustaining Pedal and the Metrostyle, Metro-Art Rolls produce effects hitherto confined entirely to the most artistic hand performances.

The Result of Long Study and Experiment

Recorded-rolls, so-called, are not a novelty. Over 15 years ago, the Aeolian Company possessed machines by which records could be taken of hand-performances, which could be subsequently transferred to Pianola Music Rolls. Not until the past few months, however, has the Aeolian

Three Recital Demonstrations this Week
 Metro-Art Music Rolls are one of the most significant developments in the history of music. They are the first of their kind. To afford owners of Pianolas and other players and all other interested in music an opportunity to hear these rolls, three recital demonstrations will be given at Aeolian Hall, 362 Fifth St., New York, on Monday, Tuesday and Wednesday, April 15, 16 and 17, at 3 P. M. Aeolian Four-Drag will be heard, and the Metro-Art Music Roll will be played upon the Pianola and interestingly explained. Admission is free and all are welcome.

PROGRAM

- | | | |
|-------------------|-----------------------|--------------|
| Labretarium | MRS. VIOLA WATERHOUSE | Soprano |
| Moonlight Song | MRS. W. H. WATKINSON | at the Piano |
| Mamma's Song | MRS. WATKINSON | at the Piano |
| Four Great Songs | MRS. WATKINSON | at the Piano |
| Harold Wren | MRS. WATKINSON | at the Piano |
| My Love's Colony | MRS. WATKINSON | at the Piano |
| Old English Songs | MRS. WATKINSON | at the Piano |

THE AEOLIAN COMPANY
AEOLIAN HALL

362 Fifth Avenue, near 34th St., New York
 Largest Manufacturers of Musical Instruments in the World

The Red Metrostyle Line is on Every Metro-Art Roll

The Immense Value of Recorded METROSTYLE Rolls

The objection to recorded rolls, as hitherto known in this country and abroad is that no matter how excellent the interpretations they portray, they play always in the same tempo and hence become finally monotonous.

This objection is entirely overcome in Metro-Art Music Rolls. While it would be exceedingly difficult, if not impossible, for the ordinary performer to almost perfectly interpret on a recorded roll, the Metrostyle Line on all Metro-Art Rolls shows precisely how this can be accomplished.

Indeed, this Line gives a separate and an additional interpretation and by indicating just the places where changes can be made, opens the way for an inexhaustible variety of effects, at the command of the performer.



The Launch of the Metro-Art, New York Sun, 17th April 1912.

Historical Background - The Initial Development of the Duo-Art, 1909 - 1910

The scene was finally set for an American assault on the German citadel of the reproducing piano. We have discussed the Ampico in a previous article, and now is the time to examine in detail the processes that culminated in the launch, on Monday 2nd March, 1914, of the Duo-Art reproducing piano.

Between 1914 and 1918, the Aeolian Company was involved in a long drawn out patent infringement case, against its competitors and industrial neighbours, Wilcox & White, manufacturers of the Angelus and Artrio player-pianos, amongst other instruments. Aeolian finally lost the battle, after various processes that seem to have ended up in the Court of Appeals for the District of Columbia in April 1918. Both companies claimed priority of invention for similar dynamic recording mechanisms, which in the case of Wilcox & White, resulted in the award of a US patent to Frank C. White, the Company's main engineer.

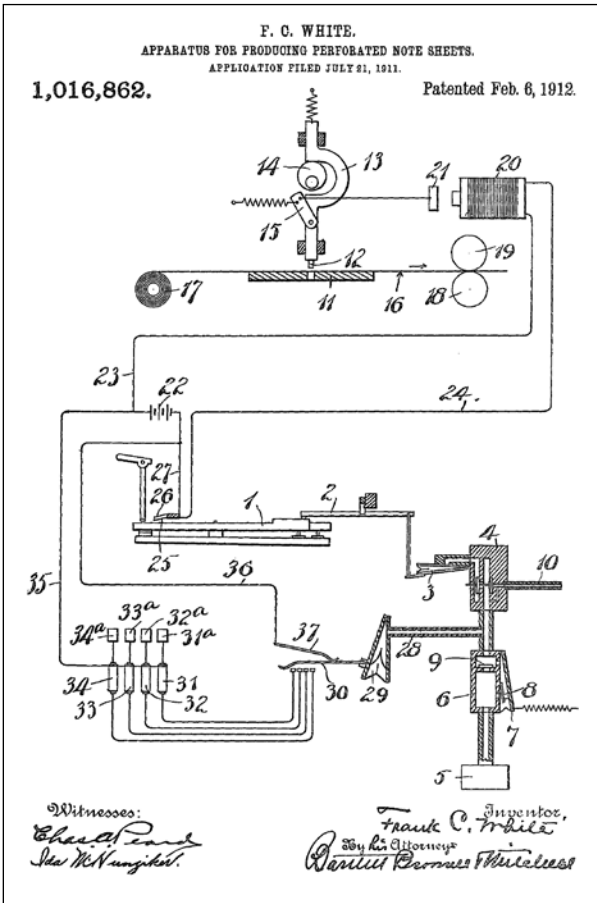

US Patent no. 1,016,862, for an Apparatus for Producing Perforated Note Sheets.

Generally speaking, the records and drawings of unsuccessful patent applications are not archived by patent authorities, and so a great deal of interesting historical information falls by the wayside. However, in patent litigation cases such as this one, the US Patent Office seems to have held on to a good selection of original documents, and so we are lucky enough to have a detailed account of the earliest development of the Aeolian Company's reproducing piano, which came to be known as the Duo-Art. The records themselves, being over a hundred years old, are not subject to copyright, and so we could in theory reproduce them in this Journal. However, they are very long, so that we should quickly run out of space, and it therefore makes more sense to upload them in due course to our website, so that those who are interested can download them as Adobe pdf files. Alas, there is another very significant problem, which is that the original papers are rather dirty, so that the scanned copies kindly provided by their current hosts, the University of Maryland, are sometimes quite difficult to read. We have been slowly cleaning them up, but this is a process that takes at least an hour per page, and that is only for the clearer ones. The main item of interest is known as *Rees Record*, being a verbatim account of the evidence provided for the Patent Office Examiner of Interferences by William H. Rees, an Aeolian Company employee, together with supporting testimony from other Aeolian staff, including Edwin Votey, Francis Young and Frederick Wood, the last-named being at the time the Superintendent of Aeolian's Meriden factory.

At the moment there are 67 pages of the Rees Record that we have assembled, consisting of William Rees' testimony in its entirety, but not yet the corroborating evidence from others, which will be added as time allows. Those interested will find what is currently available at the following web address, but this article uses the testimony of the other witnesses as well.

www.pianola.org/pdfs/rees_record.pdf

Aeolian was well aware of the existing Wilcox & White patent, which it regarded as having been incorrectly awarded, so in order to set the scene for what was clearly a deliberate attempt to provoke an interference, it is sensible to quote Edwin Votey, from written testimony that he provided in connection with a procedural hearing held on 11th April 1916.

From 1909 to March 1913, the date when Mr. Rees filed his application for a patent through Mr. Gunz, the experimental department of The Aeolian Company had been perfecting the reproducing instrument which was adapted to play with the music rolls embodying the tempo and dynamics made in accordance with the Rees invention. This instrument was afterwards called the Duo-Art Piano, which went on the market early in 1914. The first newspaper advertisement was published on March 15, 1914. [Actually it was on March 1st - ed.] During this entire period, many rolls were made according to the Rees invention and were repeatedly used as part of the reproducing instrument in the course of its evolution and development. That said music rolls and the reproducing

instrument were so vitally related and interdependent, that it was thought to be unwise to file any application for a patent on the invention for making the music rolls until the reproducing instrument was perfected for the market, and lacking such instrument, the rolls would not be beneficial or useful to the public. These rolls could not be commercially used until there was a reproducing instrument to play them. About March, 1913, the experimental work clearly demonstrated that the reproducing instrument had been sufficiently perfected to warrant the manufacture of it for commercial purposes, and the application in Interference was then filed by Rees through Mr. Gunz.'



William H. Rees (b. 1864) - c. 1918.

Photo courtesy the International Arcade Museum - www.arcade-museum.com

Edwin Votey doesn't quite say that Rees was the sole inventor of the Duo-Art, but he certainly credits him as the leading figure in its development, so a little background information about Mr Rees would not go amiss, since he is not a particularly well-known member of the Aeolian Company's staff. William H. Rees was born in Philadelphia in 1864 and initially seems to have worked as a freelance piano and organ tuner, though he was also a composer and pianist. According to his own testimony in December 1915, he had worked for the Aeolian Company, *'directly and indirectly, for about twenty years,'* presumably taking an increasing interest in roll-operated musical instruments as they came on to

the market. Around 1897 he moved from Philadelphia to Worcester, to take up a staff position of organ builder at the Aeolian Company's reed organ factory, which clearly provided him with a certain financial security, and he married Lillian Plummer in Boston in 1905. Evidently a talented inventor, he had risen to the rank of foreman by 1908, specializing in electrical and pneumatic work, especially in connection with expression devices. In 1909 he was summoned to New York and spent a few years as part of the Aeolian Experimental Department. Then, after playing a major part in the invention and development of the Duo-Art, William Rees was placed in charge of the Universal Music Company's New York music roll arranging division, with headquarters at 225, West 36th Street. His name appears on nine Duo-Art rolls as either pianist or composer, generally of the sort of popular music at which Frank Milne also excelled, and he is also regularly to be found on Metro-Art and Uni-Record selections. So we are dealing with a man whose areas of expertise ideally bridged the divide between music and pneumatic engineering.

The initial development of the Duo-Art began in January 1909, when Rees was summoned to New York at Edwin Votey's suggestion, to undertake the first practical steps towards developing a reproducing piano. In this connection it is interesting to note, as we did earlier, that the publication of new Autograph-Metrostyle rolls in the US seems to have petered out towards the end of 1908, so there is the distinct implication that the two events were in some way related. Votey asked George Kelly, director in charge of patent-related matters, to organise Rees' transfer, and on 11th January 1909 Kelly wrote to Rees, who arrived in New York less than a week later. To our modern eyes it is remarkable how quickly the transfer was effected, with Rees also moving his family to Manhattan at the beginning of February.

THE AEOLIAN COMPANY,
AEOLIAN HALL,
New York.

Jan. 11, 1908.

Mr. Wm. H. Rees,
The Vocalion Organ Company,
Worcester, Mass.

Dear Mr. Rees:

I have a piece of news to communicate to you. It may, in a way, be agreeable or not. You know that I think very highly of you as a man and your ability as an expert mechanic, and the proposed change will be a great disappointment to me, as I had many plans to work out in our line of business, and I know of no one better fitted to carry out such plans than yourself.

Our Mr. Votey is about to start work upon a very elaborate scheme of invention in the player business, and he has applied to me to release you from the Worcester factory so that you can go to work under his directions in carrying out this scheme. I suppose the work will be carried on here in New York, maybe in Garwood. I have not had a chance to ask him yet, but my opinion is that it will be at 32nd warehouse, where Mr. Pain is.

I know that you had not felt at home in Worcester, and I have sometimes thought that your health may have suffered from living there. Taking that view of it, I am sincerely glad you shall have an opportunity to come to a more congenial atmosphere and perhaps better climate.

I think Mr. Votey would like to have you at once, so it will be well for you to finish up the sub-base on that experimental organ and let the rest of it lay for the present.

If this should take more than a week, better let it go for the present.

I am writing this now so that you may make your plans accordingly. I could not reach you in Philadelphia or I would have communicated with you before.

Hoping this change will be satisfactory to you, I am,

Sincerely yours,
GEORGE B. KELLY.

Letter from George Kelly to William Rees, 11th January 1909.

In mid-January Rees began work at the Aeolian Company's Experimental Workshop, based at the time at 157, East 32nd Street, which also housed a garage and a warehouse. In 1909 this would have been fairly close to the Aeolian Hall at 362, Fifth Avenue, allowing for Edwin Votey to take an occasional constitutional and supervise the progress being made. The workshop was a small, locked room in a larger repair establishment, with space enough for two trusted members of staff. At that time the more permanent inhabitant of the shop was Robert W. Pain, one of Aeolian's most senior and prolific inventors, who in January 1909 had just reached the age of 77, remarkable for the period, especially since Pain continued inventing and applying for patents until his eightieth year. Pain kept a book of work, detailing the hours spent on various tasks, which Edwin Votey regularly consulted in order to keep a check on the Company's financial outlay.

During January and February Rees made up initial drawings of a 65-note '*recording Pianola*,' with electrical contacts attached to the equalizer of the pedal exhausters, from which dynamics could be recorded, and pneumatic tubes twinned from sixty outputs on the Pianola's primary stack to pneumatic motors and electrical contacts on a board attached to the rear of the instrument, in order to record the notes, all of which were to be cut on a real-time perforating machine. Five positions of the notional 65-note roll were reserved, initially for dynamics, but later adjusted to four dynamic positions and a sustaining pedal channel. The five dynamic levels were *pp*, *p*, *mf*, *f* and *ff*, or pianissimo, piano, mezzo-forte, forte and fortissimo, finally achieved with only four contacts because the base level was always set at pianissimo, which would occur naturally when no other levels were indicated. Three of the reserved holes were at the bass end, replacing A, Bb and B on the 65-note scale, and two at the treble, replacing C and C#.

A 65-note (push-up) Pianola, serial number 39465, was shipped to the 32nd Street workshop on 23rd January, and Rees set to work to put his ideas into practice. A 65-note real-time perforating machine that had been built by Frederick L. Wood, Superintendent of the Aeolian factory at Worcester, had already been sent up to New York in late 1908, and in March 1909 a set of 70 brass contacts followed from the same source, which Rees evidently wired up fairly quickly, because he recalled that the initial recording installation had functioned successfully by the first few days of April 1909. It is important to note that this early instrument only recorded one set of dynamics for the whole musical range, and that it was the electro-pneumatic contact board on the rear of the Pianola which signalled the notes to the perforating machine, so that there were no contacts under the keys of the attached upright piano that was used for these early experiments. Apart from that one detail of Rees' invention, he had clearly mirrored the Frank C. White patent, roughly two years before White made his application.

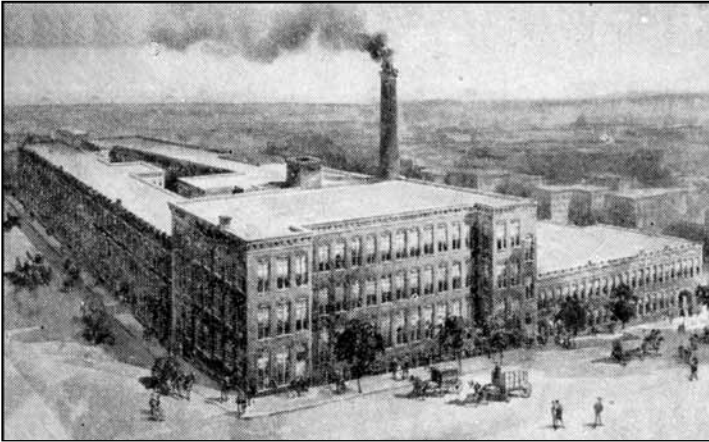

The Aeolian Company's Factory at Worcester, Massachusetts, 1905.

Rees sent the die-plate and bed-plate of the perforating machine to Fred Wood at the Aeolian factory at Meriden on 6th April, to be respectively tapered and milled out, to allow the perforated chaff to drop out more easily, together with rollers from the same machine, to cause them to grip better, and these were all returned within a week. While the machine was dismantled, he went through the solenoids, *'taking out the short circuits.'* It should be noted that Aeolian was moving its reed-organ and general metalworking activities from Worcester to Meriden at around this time, and that Fred Wood therefore moved to become the Assistant Superintendent at the latter factory, taking over from Willard S. Pain as Superintendent a few years later. These illustrations, from an advertisement in Scribner's Magazine in 1905, shows the two factories, as they would have looked at roughly the time the Duo-Art was being developed.



The Aeolian Company's Factory at Meriden, Connecticut, 1905.

Then, between April and June 1909, Rees modified a 65-note Pianola Piano, to turn it into a simple form of reproducing instrument, but by his own account the initial prototype installation needed improvement, with regard to both the perforating machine and the reproducing mechanism. In mid-June the perforator was shipped briefly back to Meriden again, and it returned on 17th June, again in a slightly dismantled state, but with selector lever extensions added, to allow Rees to attach pneumatic motors and so to furnish it with an electro-pneumatic action, which he considered would make it more sensitive than the previous straight electric mechanism.

In September 1909 Rees made drawings of a real-time roll-marking machine, which Robert Pain then constructed under his supervision. It seems very likely that this would have been a machine for marking stencils (master rolls), rather than playable rolls. One must remember that the development of 88-note rolls and player pianos was under way at this time, following the industry convention at Buffalo in December 1908. The marking of stencil rolls allowed for the production of multiple copies at the Aeolian perforating department in Meriden, and it also facilitated their conversion to 88-note stencils and rolls.

By early 1910 a combined 65/88-note Pianola had been converted in a similar way, but with extra modifications, and with the note contacts now placed under the keyboard of the associated piano. When questioned by his attorney about the differences, Rees specifically notes that, *'There was solo registration on the dynamic levers. Also electrical registration and pressure regulation from the treble and bass chest of the Pianola.'* At first reading, this statement is a little confusing: if dynamic levels were being measured in some way from the treble and bass sections of the pneumatic stack, then a further dynamic reading from the subduing levers would be superfluous. We shall return to a discussion of this detail towards the end of the first part of this article, but it is worth remarking that the reference to *'solo registration'* suggests that as early as 1910 there was an intention to experiment with a reproducing system that incorporated the Themodist. Some early Aeolian player instruments have a pair of pallet valves at the extreme right-hand end of the subduing lever travel, leaving the theme valves actuated during periods when the levers are not in use, and this practice may of itself have suggested the use of the levers for some form of on/off marking.

In addition, the intention of indicating theme perforations, together with the placing of the note contacts under the keys of a piano, points towards a realisation that a dual-purpose recording process was already envisaged, not only to produce *'temporized'* music rolls from the playing of a normal roll by a Pianolist, but also to work towards some means of directly recording the playing of pianists, while using the modified Pianola as the preferred method of dynamic capture. Since the litigation process from whose pages we are deriving this information was concerned with priority of invention, it concentrated on

the early stages of recording development, and so the account makes little mention of any period after 1911, except in connection with items of evidence that had been misplaced. Nevertheless, a fully-developed note-recording system must have been in use by late 1911, in order to prepare an initial repertoire in good time for the public launch of Metro-Art and Uni-Record rolls in April 1912.

Historical Background - An Overview of Duo-Art Development, 1908 - 1913

William Rees notes that roughly two years prior to the date of giving his main testimony in December 1915, he had placed a particular roll in his '*recording room*' (Room 636) at Aeolian Hall, and that subsequently the roll had been lost, when he vacated the room in order to take up another position within the Company. The fact that he refers to the room in such a specific way does suggest that both Metro-Art and experimental Duo-Art recording was carried out there, at least until mid-1913, after which a new and more luxurious Duo-Art suite was presumably established. It is likely that the new roll division to which Rees was transferred also played a significant part in the recording of Duo-Art rolls, and that many popular recordings such as the latest compositions of George Gershwin and Zez Confrey, for example, would in general have been made on a recording piano at these premises. Prior to 1914, Aeolian's main roll-arranging department had been located in Meriden, Connecticut, headed by an experienced Canadian musician, George Swift, but this relatively remote location would not have been so suitable for recording the hot piano styles of New York City.

Other personnel must have joined in the process of creating the Duo-Art during this time, and it might be useful to list those who almost certainly played a part. It is clear from George Kelly's 1909 letter to Rees that a Company decision had been taken in late 1908 to commence the development of a reproducing piano, presumably in response to the success of the Welte-Mignon, though Charles Stoddard had applied for his first Ampico dynamic recording patent in the April of that year, and it is possible that news somehow leaked. At any rate, the Aeolian decision would have been a matter for the Company's board, led by Harry Barnes Tremaine as President of the Aeolian, Weber Piano and Pianola Company, and advised by Edwin Scott Votey, presumably empowering the latter to take all necessary steps. These portraits of the two of them also date from 1908, that of Tremaine appearing in an advertisement in the Saturday Evening Post, but Edwin Votey is seen in a detail from a large original photograph that has survived, of an Aeolian Dinner held at the New York Athletic Club on 6th June of that year. It's a serendipitous discovery - the hair is slightly unkempt, and there is just the hint of the animated eyes that so often fail to show through the rather static photographic procedures of the times.

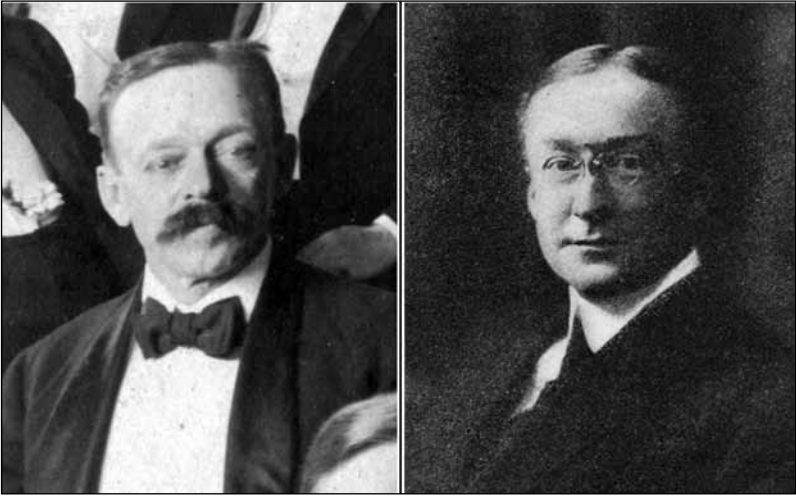

Edwin S. Votey and Harry B. Tremaine, 1908.

Passing down the chain of command, the next executive would certainly have been Francis Lincoln Young, a member of the Board of Directors with particular responsibility for musical matters. Young's participation as the notional leader of the Duo-Art project is confirmed from a somewhat unlikely source: a toast given at dinner after an Aeolian Company sports day at Tarrytown, NY, on 22nd June 1914.⁸ Lawrence Bogert, whose expertise as Head of the Retail Piano Department at Aeolian Hall was evidently matched by his skill at producing appropriate verselets, amused the assembled ranks of the Aeolian sales and office staff at a dinner that evening, after a successful afternoon of baseball.

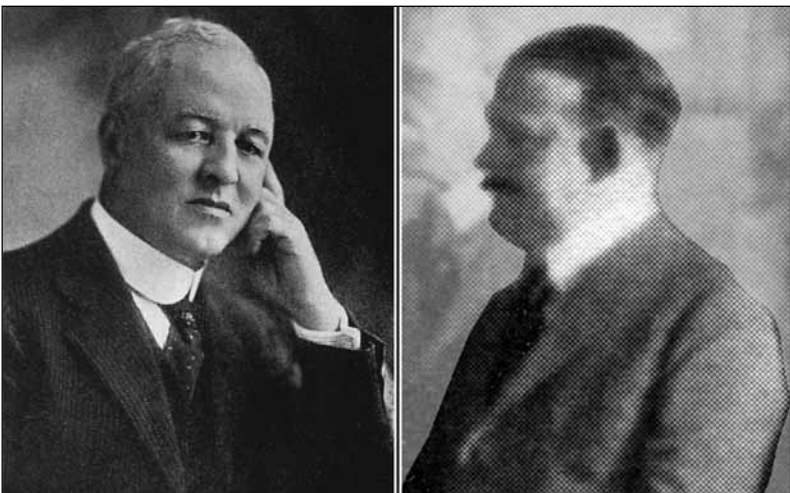

Joseph H. Dickinson, c. 1930, and Francis L. Young, 1923.

The toasts begin as follows:

*Here's to our President, worthy Tremaine,
Long life we wish him again and again;
Splendid executive, gentleman true,
Business man grand, all honors to you!*

There are twelve verses in all, and we can safely pass by the rest, since our purpose is to light on the one for Francis Young, which reads:

*Here's to our Young, the man who does things,
For, every short time a new wonder he springs,
He knows how to capture the musical heart,
And that's why he gave us the grand Duo-Art!*

One cannot read too much into a short verse, of course, but it is clear enough that Young was centrally involved with the Duo-Art, and is likely to have become the project co-ordinator, once the invention had passed beyond its initial stages.

On the engineering side, the factory staff at both Meriden and Garwood must have played a significant part in the project, as did Robert W. Pain, the doyen of Aeolian's New York Experimental Department. The Assistant Factory Superintendent at Meriden, Frederick L. Wood, commissioned the construction of the necessary real-time perforating machines from late 1908 onwards, and Joseph Hunter Dickinson, Superintendent of the Experimental Department at Garwood, must also have been an indispensable figure, because modified versions of his patented accordeon pneumatic and knife valve devices became the central features of the Duo-Art's dynamic controller. Alas, there are so far no reliable photographs of Messrs Pain or Wood.

One very significant question remains unanswered, as to who was responsible for the modification of the accordeon device from a decimal to a hexadecimal system, so that its four layers could select sixteen rather than only ten steps. This very early use of binary logic must have been something of a milestone shortly after 1910, and one has to make the assumption that the brainwave came from one of the engineers, most probably Joseph Dickinson, or perhaps even Rees himself, who does seem to have been remarkably accomplished in both the musical and technical spheres.

The legal aspects of patenting were supervised by George Kelly, a senior figure who had been in charge of the Automatic Music Paper Company, one of the two organisations that merged to become the Aeolian Organ and Music Company in 1887. Kelly's most important personal invention was arguably the slide-valve wind motor, used by Aeolian from the 1880s onwards, but which permeated the entire industry, once the duration of the patent had expired. In connection with this and other litigation processes, Kelly had able assistance from two trained lawyers, Oscar Gunz and George Beattys, and some of the delays during this particular action were occasioned by the long-drawn-out illness and subsequent death of Mr Gunz in early 1916.

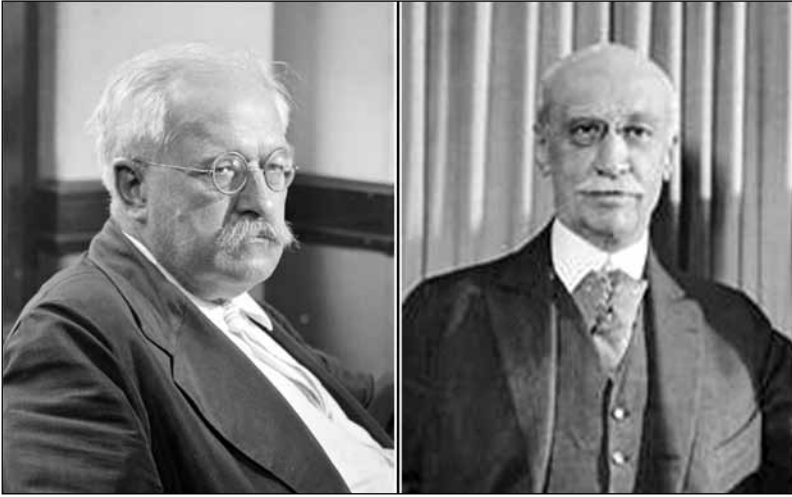

George B. Kelly, c. 1914, and George D. Beattys, c. 1925.

Finally the man who has come down to us as the main historical symbol of the Duo-Art, W. Creary Woods, joined the project, probably in the spring of 1913, in part to set up a library of suitable music rolls. In a letter written in April 1960 (at the age of seventy-eight),⁹ in reply to various questions from Arthur Sanders, who ran a private Musical Museum in Deansboro, NY, Woods describes his work for Aeolian, in a detailed account that has inevitably lost some of its accuracy by having been written between thirty and almost fifty years after the original events:

‘As to my experience with the Aeolian Company and the Duo-Art Piano, I began as a salesman with several other young men, demonstrating the Pianola and selling the Pianola rolls. Since I had studied piano for a number of years, my musical knowledge helped considerably in playing the Pianola Piano. I became quite proficient in playing the instrument and gave recitals at Aeolian Hall in New York, also at Clubs and Musical Societies outside of New York.

‘There were several inventions on the Pianola that made it easy to obtain good musical effects. Thro these inventions the Duo-Art mechanism was developed. During this period the Company developed a Recording Piano and a machine that would cut the perforations in the paper roll simultaneously while the artists played. This was a great improvement over the old method of arranging all the music on a paper stencil and cutting it out by hand.

‘As I was in the experimental department about the time the Duo-Art Piano was ready for public sale, the Company wanted me to prepare some of the Records for the Duo-Art with the artists’ assistance. This meant editing the rolls for the Duo-Art Mechanism, which was quite a task since it was something entirely new. However, it wasn’t long before I had a library of about fifty rolls ready for the catalogue.

During this time I found a much simpler way, and that was to cut the expression into the rolls as the artist played. It saved much time and improved the expression in the rolls. You will find the expression perforations in the Duo-Art rolls on the right-hand side are the solo or treble, and on the left side is the expression for the bass accompaniment. All the rolls were edited by the Pianist, who indicated to me or one of my assistants any changes they wished made. They also had to sign the roll when they finished the work. It was very interesting working with the Artists, and most of them were happy to do this work, since they also learned something about their interpretations from it.'

It is very clear that the initial method of recording expression in real-time was invented and developed, not by Creary Woods, but by William Rees. If Woods did have any input, then it was perhaps to suggest alternatives to the use of a push-up Pianola, once it became likely that the Aeolian Company would not win the patent interference case. Woods also makes the common error that the left and right expression coding perforations on a Duo-Art roll are somehow linked to the bass and treble sections of the pneumatic stack respectively, whereas in reality they exclusively affect the Accompaniment and Solo regulators, which in turn are independently directed towards the bass and/or treble as necessary, by means of the presence or absence of Themodist perforations. That particular error is such a basic one to have made, especially for the chief Duo-Art recording producer, that it makes one wonder exactly how much of a part Woods played in the editing process, once the initial roll had been recorded, though his fundamental importance to the overall project is undeniable. As we shall see, there are early photographs, from a period up to about 1916, which show him editing rolls in conjunction with a number of pianists, but there is also much evidence of other musicians sharing in this complex work, to judge from the signatures and initials of many of the trial rolls that used to be housed at the International Piano Archive at the University of Maryland, and which are now located at Stanford University in California.

The Aeolian Company deposited a considerable photographic archive at the Library of Congress in 1916, from Duo-Art recording and editing sessions which had occurred in the preceding year or so, and it is quite clear that the early dynamic recording process persisted during this time, with a push-up Pianola placed in front of a second recording piano, and often no sign of the bureau-style console that is to be seen on later photographs.¹⁰ It seems unlikely to the point of impossibility that those testifying on behalf of William Rees during the patent litigation process would have lied at all significantly, so that Rees' account of having invented and developed a recording and playback system is entirely credible. However, the many delays to the legal process, from March 1913, when Rees' initial patent application was made, to May 1918, when the final appeal to the Washington District Court failed, must inevitably have worked in Aeolian's favour, in allowing it to build up an initial repertoire of rolls, with a proven but ultimately disallowed dynamic recording system.

The Early Dynamic Recording System in Practice - Paderewski in 1915

Perhaps the best way of concluding the first part of this article is to discuss the portrait of Paderewski making Duo-Art recordings in June 1915, a full three years before he signed a contract with the Aeolian Company to do just that. The four people depicted on the photograph below are Madame Helena Paderewska, Ignacy Jan Paderewski, Hermann Bismark Schaad, at that time the Assistant Manager of the Aeolian Company, and William Creary Woods, the Duo-Art recording producer.



Paderewski Recording for the Duo-Art, New York, June 1915.

Looking at the photograph, and at many others from the same year, it is quite clear that Aeolian used two recording pianos at that time, both medium-sized Weber grands, and on other, later photographs one can see the goose-neck cables that connected the recording mechanisms to the perforating and marking machines below. There are two apparently conflicting reports of the location of the perforating room: Creary Woods, in an article published in *Music Trade Review* in December 1920, states that, *'The artist is seated at an ordinary grand piano which is connected to the cutting machine in an adjoining room.'*¹¹ However, Ina Warwick Polson, a young Canadian pianist who occasionally recorded for the Duo-Art, reported on her very recent experiences in an article in the *Winnipeg Tribune* on 19 February 1921, saying that, *'the pianist plays in his natural manner, in a special room for recording, on a grand piano which is connected with a recording instrument in the room below.'*¹² Since the cables disappeared through a hole in the floor, and since a room below would technically be an adjoining room, the floor below seems more likely.

This reproduction of the original photograph certainly has blemishes, mainly because the copy was made during a very brief visit to the Library of Congress in October 2016, simply by placing the original on a table in the open library and taking a snap, and in the time available it was impossible to avoid the reflections of the overhead lighting. There is also a version of the same photograph, taken from a signed copy that had belonged to Creary Woods, and published in an issue of the *AMICA Bulletin* for January/February 1992, as part of an article by Richard J. Howe, but that version has been cropped and therefore omits the keyboard of Paderewski's piano. This slightly fuller view gives a more explicit impression of the two musicians working together, Paderewski in the foreground, playing the notes, and Woods in the corner, endeavouring to pedal the Pianola in a way that mirrors the dynamics produced by Paderewski. Furthermore, the positioning of the two pianos in line, together with the placing of a Pianola in front of the further one, results in the producer occupying very much the same position as he was later to do with his relatively well-known console.

In order to have remained silent, the Pianola must either have had its tracker-bar sealed in some way, or more probably have had a blank roll placed over it, with Woods simply avoiding the use of the tempo lever. On the other hand, the Pianola wind-motor would normally have provided a significant bleed to the suction from the pneumatic pedals, and it might be that some way was found of simulating this lowering of the level, as the 'feel' of the pedals would otherwise have been much tighter than usual. We shall deal with the controls of the subsequent recording console in the second part of this article, but it seems reasonable to assume that by 1915 the levers and pedals of the push-up Pianola provided the same range of functions, and also that this Pianola on view is the one that Rees originally modified in early 1910, no doubt with further developments in the ensuing three years.

As we saw earlier, Rees mentions that by 1910 dynamic readings were being taken from the bass and treble sections of the stack, presumably with some form of sprung pneumatics and electrical brush contacts. In addition, it seems likely that the location of solo perforations could be indicated by the subduing levers, with the aid of contacts and relays that completed a circuit only when a secondary note contact in the recording piano was made. In a letter to Reginald Reynolds of July 9, 1923, Woods mentions the recent removal of these extra piano contacts, which were '*up close to the springs,*' thereby implying their use in earlier Duo-Art recordings.¹³ He also mentions how quietly the piano now functions, after the removal of, '*the relays which are in connection with the recording machine.*' If there were indeed electrical solenoids in use, in order to send theme signals only when two contacts were made, then the noise they would have made would have been quite significant, which might well account for the look of fierce concentration that can be seen on Paderewski's face!

Certainly one finds an unnecessarily frequent use of Themodist signals in some early Duo-Art rolls, in the days before they were marked up by hand, as part of a far less automatic process. Since Duo-Art recording was very much a co-operative venture between pianist and recording producer, the styles of editing are just as important as the technical methods of obtaining the note and dynamic records. It makes more sense to discuss these elusive techniques, which varied significantly from time to time, and between New York and London, as part of a more general survey in the next part of this article. But in concluding this brief look at the earliest days of the Duo-Art, one may note that, by roughly 1913, a system of dynamic recording based around an 88-note Aeolian Pianola appears to have been in regular use, and W. Creary Woods seems to have been the principal recording Pianolist and editor.

Postlude

The place for a sensible concluding discussion will undoubtedly be at the foot of Part Two! But a forty-page article surely needs a conclusion, you might say? Well, instead we can sound off a parting shot, by noting that too much of this information is housed in the heads of too few people, and not just with regard to the Duo-Art. Who is there, for example, under the age of seventy, who would correctly attribute the inaccuracy of some of the dotted rhythms in Edvard Grieg's *Norwegian Bridal March*, to the decision of a roll editor to alter the original perforations, (in order to allow the Welte-Mignon of 1906 enough space for note repetition), rather than blaming poor old Grieg for his failing keyboard technique? One could even imagine young pianists, seeking to perform in the style of the masters, listening to such artificial inaccuracies and regarding them as some strange form of authenticity! Similar concerns apply to roll speeds and accelerations, which have been frequently misrepresented by those who have sought to validate CD recordings, and which cannot therefore be used as a reliable basis for historical research, at least not without informed analysis and comparison with surviving 78 rpm recordings.

One particular resource that impinges on the methods of Duo-Art dynamic recording is the collection of original, trial, pattern and issued rolls that came from W. Creary Woods' private library. It remains most unlikely that these will be investigated in detail during the lifetimes of those specialists who have studied this matter in the past forty or so years, so that much of the significance of the graphic evidence risks being lost, as the playing and study of perforated rolls is replaced by electronic simulations, which at the moment ignore all the raw detail of marking up, editing and punching. In particular the editors' markings are very detailed indeed, and they need analysis, not by the librarians or museum curators who so conscientiously house and catalogue them, but by those with many years' experience of practical Duo-Art coding. Such informed study will probably never happen, and a good example of this is the existing

catalogue of the Woods rolls, which was drawn up by a group of students at the University of Maryland in 1983. Although the decision to publish was laudable, it is nevertheless replete with errors, especially in the identification of the various types of pre-publication rolls.¹⁴

Some of the rarer Maryland rolls were loaned in the 1970s to Gerald Stonehill in London, to be copied and issued as part of a private Duo-Art subscription series perforated by Gordon Iles, of Artona Music Rolls in Ramsgate. It is not entirely clear that all the rolls were returned, however, and it may be that some found their way to a collector in Moscow, via an auction of Gerald Stonehill's musical estate at Christies in London, in the early 2000s. This writer owns Gordon Iles' master rolls for most of the series, but the accuracy of the copies is distressingly low, with a resolution from the initial automatic copying process of no greater than one-sixth of an inch, improved by hand (to one-twelfth of an inch) by Mr Iles, but only in those places where he noticed the errors.

The perforation spacing on the original issued Duo-Art rolls had a punch frequency of either twenty-one or thirty-two per inch (thirty-one and a half on English rolls), and, to set this into the context of the timing of actual performances, a roll punched at thirty-two per inch, running at speed 80 (eight feet per minute) gives an accuracy in time of roughly one-fiftieth of a second at the start of the roll, increasing consistently as the paper speed (but not the performance speed) accelerates. An accuracy of only one-sixth of an inch reduces the tempo fidelity to less than one-tenth of a second, but this is again coarsened by the fact that the one-sixth sampling is taken from a roll already punched at a different rate, and not from an analogue marking. What happens to the understanding of such a performance, already severely coarsened, when it is transferred to an electronic system, where the perforation patterns are not reproduced at all? If we are to do justice to the fiercely inventive talents of the Duo-Art development team, we need to ensure that avenues are always left open for improvement, based on a continuing and informed analysis of the original rolls.

[Part Two of this article will appear in *Pianola Journal* no. 27.]

Footnotes

1. Patrick Handscombe and Terry Broadbent, *The London Duo-Art Pianists, Player Piano Group*, London, 2014.
2. *Appreciation*, The Aeolian Company, New York, n.d. (c. 1899).
3. The first three German reproducing piano systems were:
 - 1 - The *Welte-Mignon*, manufactured by Michael Welte und Soehne in Freiburg-im-Breisgau, and first exhibited under the title of 'Artist,' at the Leipzig Autumn Fair in August 1904.
 - 2 - The *Dea*, manufactured by Ludwig Hupfeld in Leipzig, and first exhibited at the Leipzig Easter Fair in March 1907.
 - 3 - The *Duca*, manufactured by J.D. Philipps und Soehne in Frankfurt, and first exhibited at the Leipzig Autumn Fair in September 1908.
4. 'Some Early History in the Music Roll Field', in *The Music Trade Review*, Vol. LIX, no. 4, New York, 25th July 1914, p.19.
5. 'Emil Sauer and the Pianola', in *The Sun*, Vol. LXVI, no. 266, New York, 24th May 1899, p.1.
6. *Die Phonola - Künstler-Musikrollen*, Ludwig Hupfeld, Leipzig, Autumn 1905, p.12.
7. Half-page Aeolian advertisement, in *The Sun*, Vol. LXXIX, no. 230, New York, 17th April 1912, p.3.
8. 'Aeolian Forces in Annual Baseball Game', in *The Music Trade Review*, Vol. LVIII, no. 26, New York, 27th June 1914, pp.51-52.
9. Copy of typed letter from W. Creary Woods, of the Delaware School of Music, to Arthur Sanders, of Deansboro, NY, 15th April 1960. (Author's collection).
10. *Library of Congress - Catalog of Copyright Entries for the Year 1916*, Part 4, Government Printing Office, Washington DC, 1916, pp.139-140.
11. W. Creary Woods, 'Regarding the Art of Reproducing', in *The Music Trade Review*, Vol. LXXI, no. 24, 11th December 1920, p.57.
12. Ina W. Polson, 'Tells Development of Mechanical Piano', in *The Winnipeg Tribune*, Vol. XXXII, no. 42, 19th February 1921, p.9.
13. Copy of typed letter from W. Creary Woods, of the Aeolian Company, New York, to Reginald Reynolds, of the Aeolian Company, London, 9th July 1923. (Author's collection).
14. *Catalog of the Reproducing Piano Roll Collection*, International Piano Archives at Maryland, University of Maryland, College Park, MD, 1983.

Claire L'Enfant and her Family -
A Vote of Thanks from all of us at the Pianola Institute
Rex Lawson



Claire L'Enfant, as we remember her. (Photo by kind permission of John Carewe.)

Claire L'Enfant, whom we also knew as Claire Cavanagh, passed away on the 22nd of August last year, very much in the bosom of her family, which is how we always knew her, really. Nick Cavanagh, her husband, her life's partner, was nearly always there when our Institute board meetings rotated to Great Percy Street, and we all watched Dan and Miranda grow from (almost!) babes in arms to the fine members of society that they have become. An obituary seems too final a term for such a warm and resourceful lady as our Claire, because she is so much in our memories that her presence will never really leave us. So this reminiscence touches on Claire's thirty-five year involvement with the Pianola Institute, and the patient and affectionate way in which she guided and cajoled us towards the publication of twenty-five Pianola Journals, as well as providing over three decades of impeccably structured Minutes. We do miss her, of course, we miss her very much, but we carry in our thoughts the gentle smile and the pat on the shoulder, both of them cushioning the firm insistence on academic and grammatical standards: *'Spell out numbers up to 100, and always single quotes and lower case for tempo markings!'*

In the early 1980s, Nick and Claire acquired a German upright player piano, a Ducanola, manufactured by J.D. Philipps and Sons in Frankfurt-am-Main. It worked after a fashion, but it needed attention, and so they turned for advice to their musical friend across the road, the orchestral conductor, John Carewe. John had recently conducted an English Bach Festival concert at the Queen Elizabeth Hall, which featured a performance of Stravinsky's *Les Noces*, unusually in the 1919 version whose instrumental accompaniment includes pianola, harmonium and two Hungarian cimbaloms. At the time, John was one of only two conductors in the world who had directed a live pianolist in concert, and so he quite naturally referred the Cavanaghs to the performer in question, who now has the nostalgic task of writing this tribute.

With Christmas 1982 in the offing, I removed many of the internal mechanisms from the Ducanola, took them back to south-east London, and worked on them, with the aim of providing a decently functioning player piano in good time for December 25th. Well, that was the intention, but there was a lot of work to do, and time passed. Christmas Eve became the final deadline, and if memory serves, the works arrived back at Great Percy Street sometime in the mid-evening, accompanied by the repairer and his new friend, Denis Hall. But everything had to be re-installed, and it grew late, and then the awful discovery was made, of the indispensable part that had somehow been left behind. An urgent motor trip was made back to the south-east, returning around 1.30 am, and the piano finally sprang into life on Christmas Day, somewhere between three o'clock in the morning and Santa's final descent down the chimney. Throughout this pneumatic ordeal, Claire and Nick remained calm, good-humoured and resourceful enough to provide copious mugs of the strong-blended coffee that we all came to relish.

A lasting friendship was forged, and over the ensuing months there was increasing talk of the founding of a Pianola Institute, and then finally in 1984 Claire became our Company Secretary. By that time she had successfully waged war with a recalcitrant firm of London solicitors which had tried to overcharge us, as well as dealing persuasively with Companies House, which had repeatedly rejected the appellation of 'Institute,' in association with such a base concept as a 'Pianola.'

Claire's quizzical smile was there to greet Londoners at the Royal Festival Hall in September 1985, for the Institute's seventy-two-hour Pianola Marathon, and her good-humoured Englishness provided an oasis of calm in the face of 120 excited young members of the Chicago Youth Symphony Orchestra, all making their London debut in the December of that year, by accompanying pianolas at the Queen Elizabeth Hall.

Without doubt, Claire made the Pianola Journal the trusted academic resource that it has become over the years, always balancing the international with the local, the rigorously technical with the musical and historical. We did our best to write Journal articles which fitted with her detailed stylesheets, and in return she always took the time to proof our fifty or so pages in minute detail, and to send the finished results to the copyright libraries which she had somehow conjured out of the ether. It was her choice to opt for the unusual paper size, a variant of octavo used mainly for art books, simply because our first issue coincided with a similar volume at the publishing house where she was a senior editor. The sizes matched, the paper was already available, and so we set out on our yellow brick road with Claire's wizardry to guide us, and we saved a few bob into the bargain!

And so it has been, during thirty-five years that have seen the gradual metamorphosis of a hobbyist's instrument into an international academic resource. We have been extraordinarily well-served by our Lincolnshire printers, Elpeeko Ltd, from the days when fresh-faced apprentices produced our journals at weekends, more or less in the owner's garage, to the present time, with printed proofs now replaced by email attachments, and 'cut and paste' photographs silently digested and reproduced by Adobe Photoshop. Claire has shepherded all of us through this digital and rollographic revolution.

But although our Pianola Institute looks outwards to the world of universities and colleges, it also has its own family of long-term friends, and the intimacies of life are as important as the grand gestures, just as they are in the music which we study and love. Sitting round the long table at Great Percy Street, eating five-star dinners before board meetings, watching Nick disappear with a grin and return with bucketfuls of variegated ice-creams; these are moments to savour just as much as the niceties of musicological research.

It was a particularly happy time when the Cavanaghs acquired the Blüthner grand Solophonola that had belonged to Bill Candy, who, as William Delasaire, had written many of the music roll reviews in Gramophone and the Musical Times in the 1920s. In the late 1970s, Bill and I had begun to talk about an institute for the player piano, and he would have been so pleased that his beloved Blüthner had found such a sympathetic home.

Claire's more public career as a world-renowned publisher was uniformly illustrious, though her wearing of that mantle was modesty itself, and indeed it took a determined search through the newspapers to discover that she had received a *Mothers at Work* award at a reception in Downing Street. For us, she was our publishing genie, our administrative rock and our constant friend. We owe Claire L'Enfant, and the whole Cavanagh family, an immense debt of gratitude for their enthusiasm, their tenacity, and indeed for their love. In return they can be certain that we shall do our collective best to safeguard the cause of the pianola, and the Pianola Institute, as they journey to whichever shores the winds of Aeolus may one day choose to carry them.

**A heartfelt vote of thanks to you all, from those whose lives you have immeasurably enriched,
The Pianola Institute.**



The Family - Nick, Claire, Miranda and Dan.

**Kenneth Caswell (1931 - 2018) - Welte-Mignon Supremo
Denis Hall**



Ken at his home in 2009.

Ken Caswell, of Austin, Texas, has died at the venerable age of 87. More than anyone else in the United States, Ken was responsible for convincing academics, pianophiles and music lovers generally of the great value to be found in the huge library of unique recordings bound up in reproducing piano rolls.

I first got to know Ken through an introduction from the Ampico enthusiast, John Farmer, who told me of Ken's work with the Welte-Mignon, and John sent me a CD of the Debussy piano rolls which Ken had made in 1991, recorded on his Feurich Welte piano. The range of tone, and in particular the delicacy of the quiet playing, were of a standard I had never previously experienced from a reproducing piano, and I asked John for Ken's address, so that I might write to him and let him know how much I had enjoyed the recordings. *'Ken never responds to letters,'* John said, *'so just phone him!'* This I did, and once I had managed to interpret Ken's heavy Texan accent, we established a rapport, and I was invited to visit Austin. From that occasion onwards, we enjoyed a very firm friendship, and I made a pilgrimage most years to Austin until his death.

I don't know when Ken first became interested in the Welte reproducing piano, but by 1962 he had fathomed out the intricacies of the system to the extent of agreeing to provide a Vorsetzer (push-up) player which was used for a box of LP records issued by the Classics Record Library (Book of the Month Club). The quality of reproduction of the rolls was way ahead of anything

anyone had heard, probably since the 1920s, although the recordings were rather spoiled in the production process. However, as a result of the success of this issue, Ken recorded a further 24 LPs for another small American label under the title *The Welte Legacy of Piano Treasures*.

In later years, Ken disowned these recordings because he felt (with some justification) that he did not have the control over the record production that he wanted, and I think he came to realise that a Vorsetzer player on a standard modern concert grand, however good tonally, did not give him the finesse of reproduction he was convinced Welte had edited in during the preparation of the rolls. As a result, by searching for a number of years, he finally found a large Feurich Welte upright piano which gave him the freedom to perfect roll reproduction to his satisfaction, and this was the piano he kept for the rest of his life.

Ken's profession was in opera and orchestral management, and during his career he had appointments in several U.S. cities, finally ending up in Austin, where the Caswell family had lived and played important roles for several generations. Moving to Austin proved to be a very fortunate coincidence, in that within easy reach of his home there lived a couple, Sandra and Karl Miller, who ran a small CD company, the Pierian Recording Society. Karl, the recording producer and engineer, was sympathetic to Ken's wish to spread the enthusiasm to a wider audience, and was happy to issue and arrange distribution of the Welte recordings which Ken could make at his leisure on the Feurich Welte piano in his home.

Thus, from the year 2000, for the rest of his life, Ken was able to have his recordings published without the pressures of commercial studio time and expense. As well as the Welte piano, Ken had a Chickering Ampico grand, and Pierian issued several CDs of popular music recorded on it, a genre to which the Ampico system is particularly well suited.

Besides his lifetime passion for piano rolls, another of Ken's interests was the collecting of 78-rpm records, mainly of popular music from the 1920s, which he remembered enjoying during what I suspect were some rather wild teenage years. He was able to make very decent CD transfers of these discs, which he circulated amongst his particular friends. From time to time I still enjoy a few tracks from one of the CDs which he gave me, bringing back memories of very happy times spent at his lakeside home.

Ken shared his wooded estate with several stray cats and a couple of dogs which he adopted. During the time I knew him, he didn't travel away from Austin, and I was never sure whether this was because of the animals he befriended, or was it perhaps that he took them as an excuse not to be persuaded to be away from home! Be that as it may, through his professional associations in Austin, through his recordings, and through his enthusiasm and knowledge, he was able to promote the great value of reproducing piano roll recordings. He was a true Southern gentleman who will be greatly missed.



Ken and John Farmer, London, June 1967.

John Farmer reminisces:-

When Ken was managing the Austin Symphony Orchestra, Alicia de Larrocha came to play the Schumann piano concerto.

I met her at a party after the concert and asked her if she had heard Ken's Welte rolls of Granados, which was a speciality of her solo recitals. She thanked me and said she would ask Ken to let her hear them.

About 10 days later, when I was back home in the U.K., she rang me up and said what she had heard was a revelation, and had caused her to change her playing style for several Granados pieces. *'You must make the BBC broadcast these Welte recordings,'* she insisted!

I was impressed by her artistic intelligence - not often found in other professional musicians, alas!



Ken and Denis Hall, Austin, February 2012.

The Metrostyle The Aeolian Company

The following article, reproduced more or less in facsimile, is taken from the very first Metrostyle Roll Catalogue, published by the Aeolian Company in New York in March 1903, but it previously appeared in *Musical Courier* magazine, in its issue for February 11th of that year, under the title *Revolutionary in Influence - A Marvelous Invention*. No author is credited, but the Editor-in-Chief of *Musical Courier* at that time was Mark Blumenberg.

The Metrostyle was invented by Francis Lincoln Young, an Aeolian Company musical specialist and sales executive, whose inventive skills led to his being placed in administrative charge of the Company's experimental and research department for a number of years, at the time when the Duo-Art reproducing piano was being developed.

Young was born in Lewiston, Maine, in 1871, and worked as a salesman in Boston during the 1890s. He moved to New York, roughly in 1898, for the launch of the Pianola, and in that connection he took part in many public demonstration concerts. But it was Charles Parkyn who seems to have become the main Pianolist at that time, and sometime after October 1900 (when his son, Ivan, was almost certainly conceived in New York), Young was sent to England, where he was based at the Orchestrelle Company, the Aeolian subsidiary which at that time ran affairs in the British Empire, Europe and South America. While there he developed and patented the Metrostyle, an undulating red line that could be printed along the length of a music roll and followed by means of a small pointer attached to the tempo lever, thus allowing a Pianolist to adhere to a previously laid out recording of tempo rubato. Whether Young actually invented the device in London, or whether he was sent there in order to develop an existing idea, away from Manhattan and the intelligence networks of rival piano player companies, remains unclear, but he seems to have returned to the US in time for the launch of the Metrostyle in early 1903, since he applied in March of that year for one of his subsequent US patents, and was once again listed as a resident of New York City.

For several years from 1903 onwards, Young made annual trips to Europe, where he co-operated with composers and other musicians in order to produce authoritative Metrostyle lines for Aeolian's Autograph-Metrostyle series of rolls. He was not the only Pianolist to undertake such duties, and, for example, George Reed of the Orchestrelle Company travelled to Bergen in 1904 and worked with Edvard Grieg, while Hermann Schaad from New York visited St Petersburg in Russia and elicited Metrostyle recordings from Rimsky-Korsakoff, Balakirev, Glazounov and Liapounov. But Young was extremely influential in the development of the Aeolian Company's musical instruments, and it is clear that he was in charge of the project to design and produce a reproducing piano, to which the Company gave the name of the Duo-Art.

The Metrostyle line remained a feature of Aeolian Company music rolls for many years, especially in Great Britain, where new Metrostyle rolls were issued until the early 1930s. Looking back from our modern vantage point, almost a hundred and twenty years since the invention was originally conceived, it is easy to smile at the dramatic rhetoric accorded to a very simple principle, but we have inherited an enormous repertoire of Metrostyle rolls, a good proportion of which bear witness to some exceptionally subtle Pianola playing. This is a huge area for future study.

Rex Lawson

THE METROSTYLE



STEREOTYPED

NEW YORK
THE AEOLIAN COMPANY
AEOLIAN HALL
362 Fifth Avenue, near 34th Street
MCMIII

THE METROSTYLE

“THE DEVELOPMENT of the self-playing instruments in this country, supplemented by their introduction in Europe, has attracted the attention of the musical world for a number of years past, particularly since the mechanical devices have become so unique as to exalt these instruments out of the class of automatic players.

By self-playing instruments are meant especially the Pianola, a portable piano-player which is moved up to the keyboard of an instrument and, by means of a perforated roll or spindle of paper, performs music that is transposed from the composition itself, no matter what the character, range, or difficulty of the composition may be. This Pianola has gradually been introduced into the best musical households, and has centered upon it the attention of the greatest musical authorities, for the reason that in its evolution it has finally succeeded in enabling the player who controls the music-roll to give certain expressions to the compositions in imitation of what the human player himself would do. Thus, for instance, a sonata, a nocturne, or a difficult composition of Liszt, full of involved passage-work, being transposed by

THE METROSTYLE

means of these perforations into the music-roll, controls thereby a set of pneumatics through which the fingers of the Pianola control the individual keys of the piano, and thereby the player of the Pianola, having at his command all of these fingers, performs these compositions at his will, giving such expression and such dynamics to it as may please his taste or fancy or his knowledge.

Piano-playing has indeed become simplified through it, for the reason that those persons who are not able to reach digital dexterity in their practice of the piano could play difficult compositions through the Pianola, and those people who have never studied piano have an opportunity to play that instrument by means of the Pianola. The rolls of music comprised in the Pianola list make a very large repertory, whereby the player is enabled to cover an enormous extent of ground, so to speak, in compositions of all kinds, and thus the Pianola has been satisfying a large demand for good music.

CONSTANT IMPROVEMENT

During all of these past years there has been a constant and gradual evolutionary improvement visible and audible in the Pianola, because the company which manufactures it—The Aeolian Company—has, by incessant application and experiment, succeeded in devising a large number of special devices that have given the player opportunities to do

THE METROSTYLE

more than merely to give an automatic repetition of the composition. A great deal of latitude has lately entered into the handling of the instrument, and it has therefore become not merely a fashionable instrument for the purpose of amusing people, but it has been utilized as a means toward education and toward the acquiring of a larger and more extensive knowledge of the musical field than formerly existed when the piano depended upon the playing of the performer directly.

The constant history of development of the Pianola has with each year brought out new phases in the shape of delicate adjustments, a finer control of the pedaling, a more positive response, and a more definite control of the fingerboard.

THE LATEST TRIUMPH

However, there was always this one defect, if we can call it such, associated with the Pianola, and that was the absence of an authority by means of which the interpretation of the important and classical compositions could be regulated in accordance with tradition or with individual ideas. The persons who played the Pianola played the compositions at will. Those people who did not understand music very naturally played those compositions according to their own expression, sometimes creating the most peculiar and conflicting results, while the musician, always, as he is, in doubt about the interpretation, could never feel assured that he

THE METROSTYLE

was correct in the performance of a composition, and the more he played the greater became his doubt. It therefore became a matter of importance that the Pianola should be developed to such a stage that compositions of the masters could be played, not only traditionally correct in expression and in dynamic contrasts, but more than that—namely, that the rolls of music could be so controlled and so marked that any authoritative interpretation could be performed by the player with absolute reliance on its correctness.

This latest triumph—one of the most marvelous things that has been invented in music—has now been accomplished by means of an attachment called the Metrostyle.

THE METROSTYLE

This is the most far-reaching achievement in the development of the Pianola, an invention by means of which it is possible to reproduce the exact interpretations of the great masters of the piano.

This Metrostyle is a finger or guide, connected with the tempo-lever of the Pianola, to which is attached a pen, and as the performer—an authority, say like Paderewski, or d'Albert, or Busoni—plays any classical or any modern composition, he guides his pen on the unwinding roll in accordance with his interpretation of the piece he is rendering, and as he plays he marks upon the roll, in red ink, a line which, as it progresses, indicates in all its

THE METROSTYLE

angles and curves exactly in expression the diminuendo, the ritardando, the accelerando, or any of the various dynamic contrasts of music just as he himself plays it. After the completion of this work on the roll the pen is removed, and any performer can use the finger or the Metrostyle, following the red line that has been marked by the composer or by the performer, and he will thereupon get an exact repetition of the performance just as it was played by the authority.

SOME EXAMPLES

We give a few examples of music that have been marked on Pianola-rolls by the authorities mentioned hereafter. In the case of Moszkowski, those compositions are his own. He marked them himself, and any one desirous of playing these compositions of Moszkowski's just as Moszkowski interprets them or desires them interpreted, can do so by means of this attachment; that is to say, the performer can play the piano compositions of Moszkowski exactly as Moszkowski desires them played, to the very lightest and most subtle shading and nuance. In the case of Paderewski the same is shown in his Theme and Variations. This is also true of Mlle. Chaminade and many others. The other compositions—for instance, the Rondo in A Minor by Mozart—has the interpretation of Paderewski, and as a guarantee the interpreters themselves place their names upon the rolls. The

THE METROSTYLE

same is the case with Harold Bauer and the compositions that have received his interpretation. In the case of Emil Paur, Beethoven's overtures arranged for the piano are selected, and these compositions are played by the Pianola according to the interpretation of Emil Paur, so that persons performing the Beethoven overtures mentioned below on the Pianola with these rolls, marked as they are, will receive exactly the same interpretation of these overtures that is given by any orchestra under Mr. Paur's direction in London or Berlin or wherever he may direct.

PADEREWSKI

Rondo in A Minor	MOZART
Theme and Variations	PADEREWSKI
Valse, Op. 34, No. 1	CHOPIN
Nocturne, Op. 37, No. 2	CHOPIN

HAROLD BAUER

Islamey	BALAKIREW
Impromptu, G flat	CHOPIN
At the Spring	LIETZ

MOSZKOWSKI

Bagatelle, Op. 63, No. 2, C Minor
Fantaisie Impromptu, Op. 6, F Major
Polonaise, Op. 17, No. 1
Serenata, Op. 15, No. 1
Valse, Op. 11
Valse, Op. 34, No. 1

THE METROSTYLE

EMIL PAUR

Fidelio	BEETHOVEN
Ruins of Athens	BEETHOVEN
Prometheus	BEETHOVEN
Egmont	BEETHOVEN
King Stephen	BEETHOVEN
Coriolanus	BEETHOVEN

THE FUTURE EFFECT

It takes considerable thought to realize what this signifies in its full bearings.

What is going to be the result of this thing? Here we have an invention which is going to be the first to perpetuate interpretations. For instance, a Chopin Nocturne can be indicated by Paderewski, by Rosenthal, by Bauer, by Busoni, by d'Albert. These five pianists all play a composition differently, and their interpretations of Chopin differ, and yet by means of the Metrostyle and the Pianola we can obtain records of Chopin Nocturnes interpreted by these five masters, and in five, twenty-five, fifty-five, or a hundred years from now people will be able to play them on the piano exactly as these pianists play them now!

Take the Moszkowski compositions which have been interpreted by Moszkowski himself. They are on record now. At any time hereafter any performer can learn exactly how Moszkowski interprets his own compositions, and the same applies to Paderewski and to d'Albert and others.

THE METROSTYLE

This will give an authoritative interpretation to be used by any one at any time on his own piano, in accordance with the roll-indications and interpretations of the composer himself.

There can be no disputes as to its interpretation. There can no longer be any question as to how Paderewski played a certain Nocturne or a composition of Schumann. There can be no question hereafter as to how d'Albert played a Beethoven or a Brahms Concerto. If any one wishes to know how the great masters interpret these different compositions, all that is necessary is to take the Pianola-roll, with the indications that are necessary, and play it.

Nothing can compare with the Pianola with its now perfected arrangement, and there is no opportunity for dispute, there is no opportunity for discussion. Here is the stamped roll, indicating exactly how the composer or conductor or the player would play or interpret or conduct the composition. Its analysis is therefore complete, and the Pianola creates a new synthesis on which to build the future musical development.

This is such a stupendous innovation on everything that has taken place in music so far that it stuns the intelligence. It is so far-reaching that it overwhelms ideals. We are completely at the mercy of an entirely new thought in musical development. We now see piano-playing taken out of the realm of automatism and placed at one step into the very highest rung of

THE METROSTYLE

the ladder of individualism. We have authoritative law from which there is no appeal. We have before us now an instrument that can gratify to the fullest extent all of our desires for a higher education in music alone in our own studio or as we wish it, and at the same time it can become a source of the most intense artistic gratification; first, because it is faultless, and, second, because it gives us food in the shape of the very highest form of individual interpretation in accordance with the number and variety of masters as they to-day are known to us.

The subsidiary advantages of this new invention are too numerous to refer to at present, such, for instance, as the development of the piano or the further diffusion of the piano as an instrument of education or pleasure. Such, for instance, as the development of composition in its application to the piano through the Pianola. Such, for instance, as an increased appetite created through the Pianola for orchestral concerts. Such, for instance, as a deeper and a more profound study of music outside of technic, because technic can now be controlled through the Pianola. In fact, there is an endless number of new phases of music that can grow out of this invention, which at once places the Pianola in the very front rank of artistic musical phenomena. In the course of the next few months a large number of the most prominent composers and players of Europe and America will have their works, as well as the works of the masters, recorded according to

THE METROSTYLE

their interpretation, and the repertory of the Pianola will therefore comprise nearly all of the great works written or adapted for the piano. What this will result in can only be conceived by musicians. The prospect is so great that it is difficult to dwell on it, but the achievement represents one of the greatest triumphs of the hour, and will have an enormous effect on the development of the music of the future."—*Musical Courier*, February 11, 1903.



Contributors

John Farmer enjoys the distinction of having persuaded a sceptical musical public of the artistic worth of the reproducing piano at a time when it was at its lowest ebb. Through his supervision of a superb series of piano roll recordings for the BBC in the early 1960s, the Ampico overnight became respectable again. He has written important articles in a number of specialist journals, notably for the National Sound Archive.

Denis Hall has been interested in recordings of pianists since his school days, when he could buy new 78 rpm records of his keyboard heroes. He first became aware of reproducing pianos in the early 1960s, and bought his first Duo-Art in 1965 (for the princely sum of £20!). These days he spends much of his time in retirement maintaining his own reproducing pianos in a condition which he hopes does justice to the virtuosi of a hundred and more years ago who entrusted their art to the piano roll recordings.

Rex Lawson is a concert pianist who has been involved in research and music making with these instruments since 1974. He has travelled with his pianola to the USA, Canada and many European countries, transporting it by plane, ship, car and even, in 1986, by gondola in Venice. He has made a special study of music written for the pianola, by the hundred or so composers who have been interested in its possibilities during the course of the twentieth century. In 2004, he gave the world premiere of *Nancarrow Concerto* for Pianola by Paul Usher. With his colleague, Denis Hall, he founded the Pianola Institute in 1985, and he is joint editor of the *Pianola Journal*.

